

# PJ Trailers

## DUMP BODY AND FLATBED TRAILERS

### **WARNING**

This User's Manual contains safety information and instructions for your trailer.

You must read this manual before loading or towing your trailer.

You must follow all safety precautions and instructions.

PJ Trailers  
PO Box 199  
Sumner, TX 75486  
800-452-9116 Phone  
903-785-687 Facsimile  
Revision 2005



Table of Contents  
DUMP BODY AND FLATBED TRAILERS

<b>1</b>	<b>WARRANTY</b> .....	<b>1</b>
1.1	WARRANTY INFORMATION .....	1
1.1.1	<i>Manufacturer's Warranty</i> .....	1
1.1.2	<i>Warranty Covers</i> .....	1
1.1.3	<i>Limitations</i> .....	1
1.1.4	<i>Warranty Void</i> .....	1
1.1.5	<i>Transportation Costs Excluded</i> .....	2
1.1.6	<i>Disclaimers</i> .....	2
1.1.7	<i>Dealer Responsibilities</i> .....	2
1.1.8	<i>Required Warranty Claim Procedure</i> .....	2
<b>2</b>	<b>GENERAL SAFETY INFORMATION</b> .....	<b>4</b>
2.1	SAFETY ALERT SYMBOLS AND SIGNAL WORDS .....	4
2.2	MAJOR HAZARDS .....	5
2.2.1	<i>Improper Sizing of the Trailer to the Tow Vehicle</i> .....	5
2.2.2	<i>Driving Too Fast</i> .....	5
2.2.3	<i>Failure to Adjust Driving Behavior When Towing a Trailer</i> .....	6
2.2.4	<i>Trailer Not Properly Coupled to the Hitch</i> .....	7
2.2.5	<i>Proper Use of Safety Chains</i> .....	8
2.2.6	<i>Proper Connection of Breakaway Brake</i> .....	8
2.2.7	<i>Matching Trailer and Hitch</i> .....	9
2.2.8	<i>Worn Tires, Loose Wheels and Lug Nuts</i> .....	9
2.2.9	<i>Improper Loading</i> .....	11
2.2.10	<i>Unsafe Load Distribution</i> .....	11
2.2.11	<i>Shifting Cargo</i> .....	13
2.2.12	<i>Inappropriate Cargo</i> .....	13
2.2.13	<i>Inoperable Brakes, Lights or Mirrors</i> .....	14
2.2.14	<i>Hazards From Modifying Your Trailer</i> .....	15
2.2.15	<i>Hazards For Dump Trailers</i> .....	15
2.2.16	<i>Hazards from Accessories</i> .....	16
2.2.17	<i>Safety Warning Labels on Your Trailer</i> .....	17
2.2.18	<i>Trailer Towing Guide</i> .....	21
2.2.19	<i>Safe Trailer Towing Guidelines</i> .....	22
2.2.20	<i>Reporting Safety Defects</i> .....	23
<b>3</b>	<b>TIRE SAFETY INFORMATION</b> .....	<b>25</b>
3.1	TRAILER TIRE INFORMATION .....	26
3.2	STEPS FOR DETERMINING CORRECT LOAD LIMIT – TRAILER .....	27
3.2.1	<i>Trailers 10,000 Pounds GVWR or Less</i> .....	28
3.2.2	<i>Trailers Over 10,000 Pounds GVWR</i> .....	29
3.3	STEPS FOR DETERMINING CORRECT LOAD LIMIT – TOW VEHICLE .....	29

Table of Contents  
DUMP BODY AND FLATBED TRAILERS

3.4	GLOSSARY OF TIRE TERMINOLOGY .....	30
3.5	TIRE SAFETY - EVERYTHING RIDES ON IT.....	35
3.5.1	<i>Safety First—Basic Tire Maintenance</i> .....	36
3.5.2	<i>Finding Your Vehicle's Recommended Tire Pressure and Load Limits</i> .....	37
3.5.3	<i>Understanding Tire Pressure and Load Limits</i> .....	37
3.5.4	<i>Checking Tire Pressure</i> .....	38
3.5.5	<i>Steps for Maintaining Proper Tire Pressure</i> .....	38
3.5.6	<i>Tire Size</i> .....	39
3.5.7	<i>Tire Tread</i> .....	39
3.5.8	<i>Tire Balance and Wheel Alignment</i> .....	39
3.5.9	<i>Tire Repair</i> .....	40
3.5.10	<i>Tire Fundamentals</i> .....	40
3.5.10.1	Information on Passenger Vehicle Tires .....	40
3.5.10.2	UTQGS Information .....	43
3.5.10.3	Additional Information on Light Truck Tires .....	43
3.5.11	<i>Tire Safety Tips</i> .....	44
<b>4</b>	<b>COUPLING TO THE TOW VEHICLE</b> .....	<b>46</b>
4.1	USE AN ADEQUATE TOW VEHICLE AND HITCH .....	46
4.1.1	<i>Trailer Information</i> .....	46
4.1.2	<i>Tow Vehicle</i> .....	48
4.2	COUPLING AND UNCOUPLING THE TRAILER .....	49
4.2.1	<i>Various Coupler Designs</i> .....	51
4.3	BUMPER PULL TRAILERS .....	51
4.3.1	<i>Trailer with Ball Hitch Coupler</i> .....	51
4.3.1.1	Before Coupling The Trailer To The Tow Vehicle.....	52
4.3.1.2	Prepare The Coupler and Hitch.....	54
4.3.1.3	Couple The Trailer To The Tow Vehicle.....	54
4.3.2	<i>Trailer with Ring and Pintle Coupler</i> .....	55
4.3.2.1	Before Coupling The Trailer To The Tow Vehicle.....	56
4.3.2.2	Prepare The Ring and Pintle .....	57
4.3.2.3	Couple The Trailer To The Tow Vehicle.....	57
4.3.3	<i>Rig The Safety Chains – Bumper Pull Trailers</i> .....	58
4.3.4	<i>Connect The Electrical Cable – Bumper Pull Trailers</i> .....	59
4.3.5	<i>Attach and Test Electric Breakaway Brake System – Bumper Pull Trailers</i> .....	60
4.3.6	<i>Uncoupling Bumper Pull Trailer</i> .....	63
4.4	GOOSENECK TRAILER WITH BALL COUPLER .....	63
4.4.1	<i>Before Coupling The Trailer To The Tow Vehicle</i> .....	65
4.4.2	<i>Prepare The Ball And Ball Receiver</i> .....	66
4.4.3	<i>Couple The Trailer To The Tow Vehicle</i> .....	66
4.4.4	<i>Rig The Safety Chains</i> .....	68

Table of Contents

DUMP BODY AND FLATBED TRAILERS

4.4.5	Connect The Electrical Cable.....	69
4.4.6	Attach and Test The Breakaway Brake System.....	70
4.4.7	Uncoupling Gooseneck Trailer With Ball Coupler .....	73
4.5	TONGUE WEIGHT.....	74
4.6	CHECKING TONGUE WEIGHT .....	76
4.7	ADJUST BUMPER PULL TRAILER HITCH HEIGHT .....	77
4.8	ADJUST GOOSENECK COUPLER HEIGHT .....	78
<b>5</b>	<b>LOADING AND UNLOADING A DUMP TRAILER.....</b>	<b>81</b>
5.1	LOADING FIXED LOADS.....	83
5.2	LOADING AND UNLOADING BULK MATERIALS.....	85
5.2.1	Prepare Trailer For Loading .....	86
5.2.2	Loading Bulk Material .....	87
5.2.3	Unload Bulk Material Using The Spreader Gate.....	88
5.2.4	Unload Bulk Material Using The Swing Gates .....	92
5.3	HYDRAULIC COMPONENTS .....	95
5.4	BODY PROP .....	96
5.5	SECURING THE CARGO.....	97
<b>6</b>	<b>LOADING AND UNLOADING A FLATBED TRAILER.....</b>	<b>98</b>
6.1	GENERAL INFORMATION.....	99
6.2	DOVETAIL AND RAMP OPTIONS .....	99
6.2.1	Hydraulically Operated Dovetail.....	100
6.2.2	Fold Down Ramps.....	102
6.2.3	Spring Loaded Ramps.....	103
6.2.4	Mesh Ramps .....	103
6.2.5	Removable Ramps .....	104
6.3	DISTRIBUTING THE CARGO .....	105
6.3.1	Preparing the Trailer for Loading.....	106
6.3.2	Loading a Rigid-Deck Trailer .....	106
6.3.3	Loading a Tilt Deck Trailer.....	107
<b>7</b>	<b>CHECKING THE TRAILER BEFORE AND DURING EACH TOW</b>	
	<b>109</b>	
7.1	PRE-TOW CHECKLIST.....	109
7.2	MAKE REGULAR STOPS .....	109
<b>8</b>	<b>BREAKING-IN A NEW TRAILER.....</b>	<b>110</b>
8.1	RETIGHTEN LUG NUTS AT FIRST 10, 25 & 50 MILES.....	110
8.2	ADJUST BRAKE SHOES AT FIRST 200 MILES .....	110
8.3	SYNCHRONIZING THE BRAKE SYSTEMS .....	111
8.4	TIRE PRESSURE.....	111

Table of Contents  
DUMP BODY AND FLATBED TRAILERS

<b>9</b>	<b>ACCESSORIES .....</b>	<b>112</b>
9.1	ACCESSORY BATTERY .....	112
<b>10</b>	<b>INSPECTION, SERVICE &amp; MAINTENANCE .....</b>	<b>113</b>
10.1	INSPECTION, SERVICE & MAINTENANCE SUMMARY CHARTS .....	113
10.2	INSPECTION AND SERVICE INSTRUCTIONS .....	116
10.2.1	<i>Axle Bolts, Frame, Suspension, &amp; Structure.....</i>	<i>116</i>
10.2.2	<i>Trailer Structure.....</i>	<i>117</i>
10.2.2.1	Fasteners and Frame Members.....	117
10.2.2.2	Welds .....	117
10.2.3	<i>Trailer Brakes.....</i>	<i>118</i>
10.2.3.1	Brake Shoes and Drums.....	118
10.2.3.2	Manually Adjusting Brake Shoes.....	118
10.2.3.3	Brakes, Electric .....	119
10.2.3.4	Tow Vehicle Operated Electric Brakes.....	120
10.2.3.5	Magnets for all Electric Brakes.....	120
10.2.3.6	Brakes, Hydraulic (vacuum, air or electric operated).....	120
10.2.4	<i>Trailer Connection to Tow Vehicle.....</i>	<i>121</i>
10.2.4.1	Bumper Pull Coupler and Ball .....	121
10.2.4.2	Ring and Pintle.....	122
10.2.4.3	Gooseneck Ball Receiver .....	123
10.2.5	<i>Landing Leg or Jack.....</i>	<i>123</i>
10.2.6	<i>Lights and Signals .....</i>	<i>123</i>
10.2.7	<i>Accessory Battery.....</i>	<i>123</i>
10.2.8	<i>Tires.....</i>	<i>124</i>
10.2.9	<i>Wheel Rims.....</i>	<i>124</i>
10.2.10	<i>Wheel Bearings.....</i>	<i>125</i>
10.2.11	<i>Lubrication Points – Dump Trailers.....</i>	<i>125</i>
10.2.12	<i>Lug Nuts .....</i>	<i>128</i>

# 1 WARRANTY

## 1.1 WARRANTY INFORMATION

### 1.1.1 Manufacturer's Warranty

P.J. trailers warrants that it's product to the original purchaser will be free of defect(s) for a period of one (1) year, providing that the following conditions are met and satisfied.

### 1.1.2 Warranty Covers

This one (1) year warranty covers the main frame, ramps, cross members, railing and sub-frame only. Normal wear items will not be replaced due to wear. These normal wear items include but are not limited to flooring, paint, brake lining(s), bearings and hoses. All auxiliary parts such as brakes, calipers, jacks, wheels, bearings, tires, suspension, lights, hydraulic dump cylinder and controls are covered by the warranty of their manufacturer.

### 1.1.3 Limitations

The sole responsibility of P.J. Trailers under this limited warranty shall be to repair and replace parts at the P.J. Trailers factory, or at a P.J. Trailers authorized dealer, or another location (with prior written approval by P.J. Trailers). All other obligations or liabilities, including incidental or consequential damages or contingent liabilities arising out of the failure of any parts to operate properly are hereby excluded, including but not limited to any damages resulting from loss of use, inconvenience, loss of time, commercial loss, or any other type of damages general or specific, foreseen or unforeseen, unless applicable state law provides otherwise. P.J. Trailers will not reimburse any claimant for any adjustment or repair of a P.J. Trailers trailer without prior written approval by P.J. Trailers. Any repairs performed at a location other than P.J. Trailers manufacturing, will be allotted \$25.00 per hour for labor costs.

### 1.1.4 Warranty Void

P.J. trailers is not responsible for damage caused by accident, negligence, abuse, misapplication, or misuse of a trailer or any of its component parts. Loading in excess of gross vehicle load rating stated on the

# Warranty

certificate plate will invalidate any and all warranties. Any modifications, alterations, or repair to any product manufactured by P.J. Trailers without P.J. Trailers prior knowledge and written consent will void manufacturer's warranty.

## **1.1.5 Transportation Costs Excluded**

Transportation of any trailer to and/or from your dealer, or an approved repair facility, or P.J. Trailers factory shall be the responsibility of the trailer owner. P.J. Trailers shall not be held responsible for any such costs.

## **1.1.6 Disclaimers**

This warranty is expressly given in lieu of all other warranties and representations. P.J. Trailers makes no representation or warranty of any kind, express or implied, with respect to P.J. Trailers weather as to merchantability, fitness for a particular purpose or any other matter. No one, including an authorized P.J. Trailers dealer is authorized to make further or additional warranties on behalf of P.J. Trailers.

## **1.1.7 Dealer Responsibilities**

The dealer is responsible for submitting the manufacturer any claim you wish to make under this Limited Warranty.

## **1.1.8 Required Warranty Claim Procedure**

1. Within five (5) days after discovering a problem with your P.J. Trailers trailer, return your trailer for inspection to your P.J. Trailers dealer where you bought your trailer.
2. If your dealer cannot repair the problem free of charge and you want to file a claim under this warranty, your local dealer must send to P.J. Trailers by registered letter or fax a warranty claim form, together with all the required information within ten (10) days of the discovery of your defect.
3. P.J. Trailers will acknowledge such receipt of a claim by registered letter or fax to the dealer and the claimant. P.J. Trailers will respond as soon as possible, being later than thirty (30) days after receipt of the claim.
4. Any defected parts must be sent by prepaid freight to P.J. Trailers, in order to qualify the claimant for replacement or reimbursement under this limited warranty. Any defective parts must be returned to P.J.

## Warranty

Trailers WITHIN THIRTY (30) DAYS OF THE DATE OF APPROVAL TO QUALIFY FOR REIMBURSEMENT.

5. P.J. Trailers reserves the right to not pay unreasonable cost for replacement or repair of defects to a P.J. Trailers trailer, and may at it's discretion, establish reasonable reimbursement or parts for any authorized work performed under the terms of this Limited Warranty.
6. When required, photos of defective part(s), or the actual part(s), may have to accompany the warranty approval before payment can or will be made.
7. P.J. Trailers HERE MAKES NO OTHER EXPRESS OR IMPLIED WARRANTIES AND THERE ARE NO OTHER WARRANTIES WHICH EXTEND BEYOND THOSE DESCRIBED IN THE USER'S MANUAL.

## 2 GENERAL SAFETY INFORMATION

### 2.1 SAFETY ALERT SYMBOLS AND SIGNAL WORDS

An Owner's Manual that provides general trailer information cannot cover all of the specific details necessary for the proper combination of every trailer, tow vehicle and hitch. Therefore, you must read, understand and follow the instructions given by the tow vehicle and trailer hitch manufacturers, as well as the instructions in this manual. Our trailers are built with components produced by various manufacturers. Some of these items have separate instruction manuals. Where this manual indicates that you should read another manual, and you do not have that manual, call PJ Trailers at 800-452-9116 for a free copy.

The safety information in this manual is denoted by the safety alert symbol:  The level of risk is indicated by the following signal words.

#### **Danger**

**DANGER** – Immediate hazards which **WILL** result in severe personal injury or death if the warning is ignored.

#### **WARNING**

**WARNING** – Hazards or unsafe practices which **COULD** result in severe personal injury or death if the warning is ignored.

#### **Caution**

**CAUTION** – Hazards or unsafe practices which could result in minor or moderate injury if the warning is ignored.

#### **Notice**

**NOTICE** – Practices that could result in damage to the trailer or other property.

# General Safety Information

## 2.2 MAJOR HAZARDS

Loss of control of the trailer or trailer/tow vehicle combination can result in death or serious injury. The most common causes for loss of control of the trailer are:

- Improper sizing the trailer for the tow vehicle, or vice versa.
- Excessive Speed: Driving too fast for the conditions.
- Failure to adjust driving behavior when towing a trailer.
- Overloading and/or improper weight distribution.
- Improper or mis-coupling of the trailer to the hitch.
- Improper braking and steering under sway conditions.
- Not maintaining proper tire pressure.
- Not keeping lug nuts tight.

### 2.2.1 Improper Sizing of the Trailer to the Tow Vehicle.

Trailers that weigh too much for the towing vehicle can cause stability problems, which can lead to death or serious injury. Furthermore, the additional strain put on the engine and drive-train may lead to serious tow vehicle maintenance problems. For these reasons the maximum towing capacity of your towing vehicle should not be exceeded. The towing capacity of your tow vehicle, in terms of maximum Gross Trailer Weight (GTW) and maximum Gross Combined Weight Rating (GCWR) can be found in the tow vehicles Owner's Manual.

### **Danger**

Use of an under-rated hitch, ball or tow vehicle can result in loss of control leading to death or serious injury.

Make certain your hitch and tow vehicle are rated for your trailer.

### 2.2.2 Driving Too Fast

With ideal road conditions, the maximum recommended speed for safely towing a trailer is 60 mph. If you drive too fast, the trailer is more likely to sway, thus increasing the possibility for loss of control. Also your tires may overheat, thus increasing the possibility of a blowout.

## General Safety Information

### WARNING

Driving too fast for conditions can result in loss of control and cause death or serious injury.

Adjust speed down when towing trailer.

### **2.2.3 Failure to Adjust Driving Behavior When Towing a Trailer**

When towing a trailer, you will have decreased acceleration, increased stopping distance, and increased turning radius (which means you must make wider turns to keep from hitting curbs, vehicles, and anything else that is on the inside corner). Furthermore the trailer will change the handling characteristics of your towing vehicle, making it more sensitive to steering inputs and more likely to be pushed around in windy conditions or when being passed by large vehicles. In addition, you will need a longer distance to pass, due to slower acceleration and increased length. With this in mind:

- Be alert for slippery conditions. You are more likely to be affected by slippery road surfaces when driving a tow vehicle with a trailer, than driving a tow vehicle without a trailer.
- Anticipate the trailer “swaying.” Swaying can be caused by excessive steering, wind gusts, roadway edges, or by the trailer reaction to the pressure wave created by passing trucks and busses.
- When encountering trailer sway take your foot off the gas, and steer as little as possible in order to stay on the road. Use small “trim-like” steering adjustments. Do not attempt to steer out of the sway; you’ll only make it worse. Also do not apply the tow vehicle brakes to correct trailer swaying. On the other hand, application of the trailer brakes alone will tend to straighten out the combination, especially when going downhill.
- Check rearview mirrors frequently to observe the trailer and traffic.
- Use lower gear when driving down steep or long grades. Use the engine and transmission as a brake. Do not ride the brakes, as they can overheat and become ineffective.
- Be aware of your trailer height, especially when approaching bridges, roofed areas and around trees.

## General Safety Information

### 2.2.4 Trailer Not Properly Coupled to the Hitch

It is critical that the trailer be securely coupled to the hitch, and that the safety chains and emergency breakaway brake lanyard are correctly attached. Uncoupling may result in death or serious injury to you and to others.

#### **WARNING**

Proper selection and condition of the coupler and hitch are essential to safely towing your trailer. A loss of coupling may result in death or serious injury.

- Be sure the hitch load rating is equal to or greater than the load rating of the coupler.
- Be sure the hitch size matches the coupler size.
- Observe the hitch for wear, corrosion and cracks before coupling. Replace worn, corroded or cracked hitch components before coupling the trailer to the tow vehicle.
- Be sure the hitch components are tight before coupling the trailer to the tow vehicle.

#### **WARNING**

An improperly coupled trailer can result in death or serious injury.

Do not move the trailer until:

- The coupler is secured and locked to hitch;
- The safety chains are secured to the tow vehicle; and
- The trailer jack(s) are fully retracted.

Do not tow the trailer on the road until:

- Tires and wheels are checked;
- The trailer brakes are checked;
- The breakaway switch is connected to the tow vehicle;
- The load is secured to the trailer; and
- The trailer lights are connected and checked.

## General Safety Information

### **2.2.5 Proper Use of Safety Chains**

If your trailer comes loose from the hitch for any reason, we have provided safety chains so that control of the trailer can still be maintained.

#### **WARNING**

Improper rigging of the safety chains can result in loss of control of the trailer and tow vehicle, leading to death or serious injury, if the trailer uncouples from the tow vehicle.

- Fasten chains to frame of tow vehicle. Do not fasten chains to any part of the hitch unless the hitch has holes or loops specifically for that purpose.
- Cross chains underneath hitch and coupler with enough slack to permit turning and to hold tongue up, if the trailer comes loose.

### **2.2.6 Proper Connection of Breakaway Brake**

If equipped with brakes your trailer will be equipped with a breakaway brake system that can apply the brakes on your trailer if your trailer comes loose from the hitch for any reason. You will have a separate set of instructions for the breakaway brake if your trailer is so equipped. The breakaway brake system, including battery, must be in good condition and properly rigged to be effective.

# General Safety Information

## WARNING

An ineffective or inoperative breakaway brake system can result in a runaway trailer, leading to death or serious injury if the coupler or hitch fails.

The breakaway lanyard must be connected to the tow vehicle, and NOT to any part of the hitch.

Before towing the trailer, test the function of the breakaway brake system. If the breakaway brake system is not working, do not tow the trailer. Have it serviced or repaired.

### **2.2.7 Matching Trailer and Hitch**

## Danger

Use of a hitch with a load rating less than the load rating of the trailer can result in loss of control and may lead to death or serious injury.

Use of a tow vehicle with a towing capacity less than the load rating of the trailer can result in loss of control, and may lead to death or serious injury.

Be sure your hitch and tow vehicle are rated for the Gross Vehicle Weight Rating (GVWR) of your trailer.

### **2.2.8 Worn Tires, Loose Wheels and Lug Nuts**

Just as with your tow vehicle the trailer tires and wheels are important safety items. Therefore, it is essential to inspect the trailer tires before each tow.

If a tire has a bald spot, bulge, cut, cracks, or is showing any cords, replace the tire before towing. If a tire has uneven tread wear, take the trailer to a dealer service center for diagnosis. Uneven tread wear can be caused by tire imbalance, axle misalignment or incorrect inflation.

Tires with too little tread will not provide adequate frictional forces on wet roadways and can result in loss of control, leading to death or serious injury.

Improper tire pressure causes increased tire wear and may reduce trailer stability, which can result in a tire blowout or possible loss of control.

## General Safety Information

Therefore, before each tow you must also check the tire pressure. Remember, the proper tire pressure is listed on the Certification / VIN label, normally mounted on the front left side of the trailer, and should be checked when tires are cold. Allow 3 hours cool-down after driving as much as 1 mile at 40 mph before checking tire pressure.

### WARNING

Improper tire pressure may cause unstable trailer. Blowout and loss of control may occur. Death or serious injury can result.

Make sure of proper tire pressure before towing trailer. Inflate tires to pressure stated on the Certification / VIN label.

The tightness of the lug nuts is very important in keeping the wheels properly seated to the hub. Before each tow, check to make sure they are tight.

### WARNING

Metal creep between the wheel rim and lug nuts (bolts) will cause rim to loosen.

Death or injury can occur if wheel comes off.

Tighten lug nuts (bolts) before each tow.

The proper tightness (torque) for lug nuts and tightening sequence is listed in Section 10.2.12 of this manual. Use a torque wrench to tighten the lug nuts and use the crisscross star pattern sequence.

Lug nuts are also prone to loosen after first being assembled. When driving a new trailer (or after wheels have been remounted), check to make sure they are tight after the **first** 10, 25 and 50 miles of driving and before each tow thereafter.

Failure to perform this check can result in a wheel separating from the trailer and a crash, leading to death or serious injury.

## General Safety Information

### WARNING

Lug nuts are prone to loosen after being first assembled. Death or serious injury can result.

Check lug nuts for tightness on a new trailer, and after re-mounting a wheel at 10, 25 and 50 miles.

### WARNING

Inadequate lug nut torque can cause a wheel separating from the trailer, leading to death or serious injury can result.

Be sure lug nuts are tight before each tow.

### **2.2.9 Improper Loading**

The total weight of the load you put in or on the trailer, plus the empty weight of the trailer itself, must not exceed the trailer's Gross Vehicle Weight Rating (GVWR). If you do not know the empty weight of the trailer plus the cargo weight, you must weigh the loaded trailer at a commercial scale. In addition, you must distribute the load in the trailer such that the load on any axle does not exceed the Gross Axle Weight Rating (GAWR). If your trailer is equipped with a Tire & Loading Information Placard, mounted next to the Certification / VIN label, the cargo capacity weight stated on that placard is only a close estimate. The GVWR and GAWR's are listed on the Certification / VIN label mounted on the front left side of the trailer.

### WARNING

An overloaded trailer can result in failure or in loss of control of the trailer, leading to death or serious injury.

Never load a trailer so that the weight on any tire exceeds its rating.

Never exceed the trailer Gross Vehicle Weight Rating (GVWR).

Never exceed an axle Gross Axle Weight Rating (GAWR).

### **2.2.10 Unsafe Load Distribution**

Improper front / rear load distribution can lead to poor trailer sway stability or poor tow vehicle handling. Poor trailer sway stability results

## General Safety Information

from tongue weights that are too low, and poor tow vehicle stability results from tongue weights that are too high. Refer to the Chapter heading “Loading the Trailer” for more information.

In the following table, the second column shows the rule of thumb percentage of total weight of the trailer plus its cargo (Gross Trailer Weight, or “GTW”) that should appear on the tongue of the trailer. For example, a trailer with a gooseneck hitch, with a loaded weight of 12,000 pounds, should have 20-25% of 12,000 pounds (2400-3000 lbs.) on the gooseneck.

A dump trailer will have the proper weight distribution if the load is **evenly distributed** in the dump body. For non-flowable (discrete) loads locate the load such as to provide the proper tongue weight. After loading, be sure to check that none of the axles are overloaded.

Tongue Weight as a Percentage of Loaded Trailer Weight	
Type of Hitch	Percentage
Ball Hitch (or Bumper Hitch)	10-15% for large trailers 6-10% for smaller utility trailers
Gooseneck Hitch	20-25%
Fifth Wheel Hitch	

Uneven left / right load distribution can cause tire, wheel, axle or structural failure. Be sure your trailer is evenly loaded left / right. Towing stability also depends on keeping the center of gravity as low as possible.

## General Safety Information

### WARNING

Improper tongue weight (load distribution) can result in loss of control of the trailer, leading to death or serious injury.

Make certain that tongue weight is within the allowable range.

Be sure to:

- Distribute the load front-to-rear to provide proper tongue weight (see chart). For dump trailers, a flowable load should be evenly distributed throughout the body.
- Distribute the load evenly, right and left.
- Keep the center of gravity low.

### **2.2.11 Shifting Cargo**

Since the trailer “ride” can be bumpy and rough, you must secure your cargo so that it does not shift while the trailer is being towed.

### WARNING

A shifting load can result in failure, or to loss of control of the trailer, and can lead to death or serious injury.

You must tie down all loads with proper sized fasteners, ropes, straps, etc. to prevent the load from shifting while trailering.

If the door latch is equipped with a catch that has a hole for a linchpin, use a linchpin to prevent the door latch from opening.

### WARNING

If the door opens, your cargo may be ejected onto the road, resulting in death or serious injury to other drivers.

Always secure the door latch after closing. Place a linchpin in the catch.

### **2.2.12 Inappropriate Cargo**

Your trailer may be designed for specific cargo, for example, only for horses. If your trailer is designed for specific cargo, only carry that cargo in the trailer. A trailer must not be used to carry certain items,

## General Safety Information

such as people, containers of hazardous substances or containers of flammable substances.

### WARNING

Never transport people inside or on your trailer. Besides putting their lives at risk, the transport of people may be illegal.

### WARNING

Do not transport flammable, explosive, poisonous or other dangerous materials in your trailer.

The exception is fuel in the tank of a vehicle or equipment being hauled.

### **2.2.13 Inoperable Brakes, Lights or Mirrors**

Be sure that the electric brakes and all of the lights on your trailer are functioning properly before towing your trailer. Electric brakes and lights on a trailer are controlled via a connection to the tow vehicle, generally a multi-pin electrical connector. Check the trailer tail lights by turning on your tow vehicle headlights. Check the trailer brake lights by having someone step on the tow vehicle brake pedal while you look at trailer lights. Do the same thing to check the turn signal lights.

If your trailer has electric brakes, your tow vehicle will have an electric brake controller that sends power to the trailer brakes. Before towing the trailer on the road, you must operate the brake controller while trying to pull the trailer in order to confirm that the electric brakes operate. While towing the trailer at less than 5 mph, manually operate the electric brake controller in the tow vehicle cab. You should feel the operation of the trailer brakes.

If your trailer has hydraulic “surge” brakes, pull the emergency break-away brake lanyard to check the operation of the surge mechanism.

# General Safety Information

## WARNING

Improper electrical connection between the tow vehicle and the trailer will result in inoperable lights and electric brakes, and can lead to collision.

Before each tow:

- Check that all lights and turn signals work.
- Check that the electric brakes work by operating the brake controller inside the tow vehicle.

Standard mirrors usually do not provide adequate visibility for viewing traffic to the sides and rear a towed trailer. You must provide mirrors that allow you to safely observe approaching traffic.

### **2.2.14 Hazards From Modifying Your Trailer**

Before making any alteration to your trailer, contact your dealer or PJ Trailers at 800-452-9116 and describe the alteration you are contemplating. Alteration of the trailer structure or modification of your trailer must be performed only by qualified technicians who are familiar with your trailer.

### **2.2.15 Hazards For Dump Trailers**

A dump trailer is specifically designed for hauling cargo that is to be dumped or in some cases, transporting equipment. A dump trailer is not designed for transporting livestock. The major hazards associated with dump trailers are:

- Overloading.
- Improper weight distribution; both side to side and front to back.
- Getting under a raised dump body.
- Not using, or improperly using the body prop.
- Modifying or altering hydraulic components.
- Modifying or altering dump controls.
- Not dumping from a solid and level foundation.
- Not fully opening rear doors when dumping.
- Jerking the trailer, or hydraulics, to loosen the load.
- Trailer contacting or coming near overhead power lines when body is raised.

## General Safety Information

### WARNING

A soft and/or uneven surface may cause the tow vehicle and trailer to tip over when the dump body is raised.

Raise the dump body **ONLY** if the tow vehicle and trailer are both on a firm and level surface.

### WARNING

An overloaded trailer or improperly distributed load can result in death or serious injury.

An overloaded trailer can cause the hydraulic system to malfunction, resulting in the dump body falling.

A load that is improperly distributed in the trailer can result in the trailer tipping over when the dump body is raised.

### Danger

**NEVER** alter or substitute any hydraulic system component. Death or serious injury may result.

An altered or component substituted hydraulic system may malfunction, resulting in the dump body falling without warning.

**NEVER** alter or substitute any hydraulic system component.

### WARNING

Risk of electrocution.

- Dump body coming near or contacting power lines can cause electrocution. Electrocution can occur without contact.
- Be sure there are no overhead power lines over or near the trailer before raising dump body.

### **2.2.16 Hazards from Accessories**

The “Accessories” chapter of this manual contains some information about certain optional accessories that may be on your trailer. Read and follow all of these instructions before operating the accessories.

# General Safety Information

## 2.2.17 Safety Warning Labels on Your Trailer

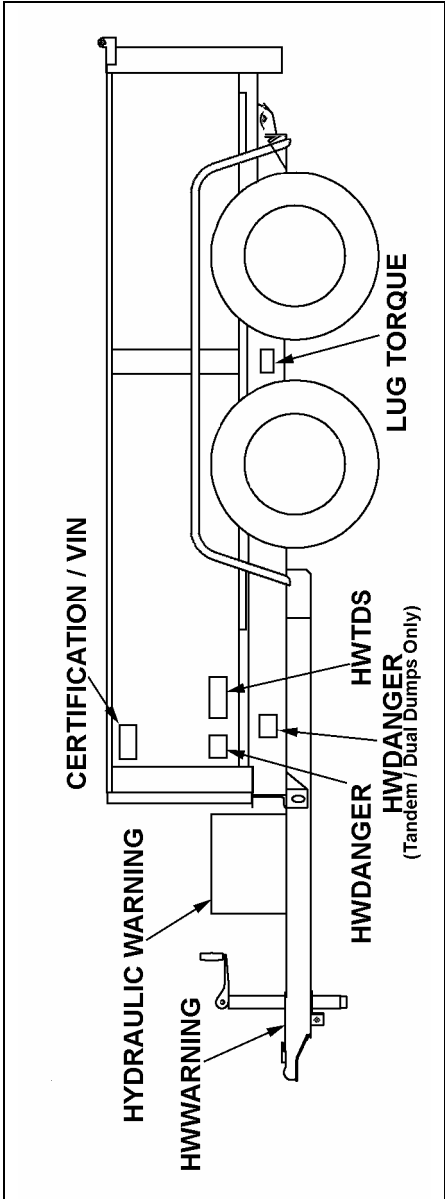

Safety Warning Labels – Bumper Pull Dump Trailer

# General Safety Information

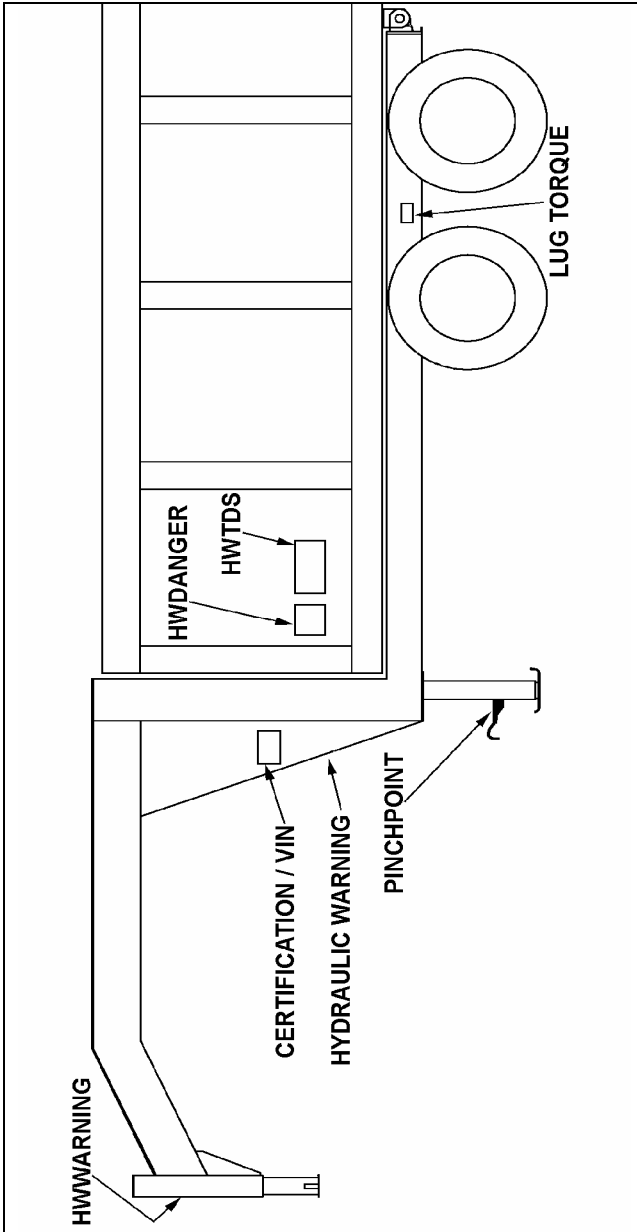

Safety Warning Labels – Gooseneck Dump Trailer

# General Safety Information

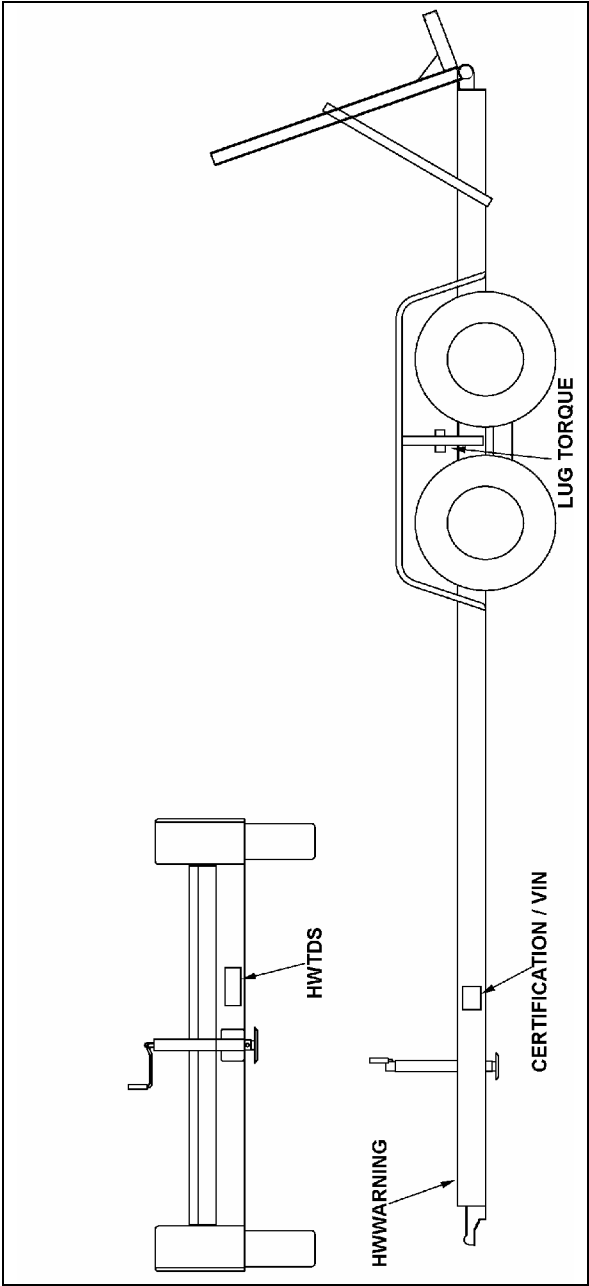

Safety Warning Labels – Bumper Pull Utility Trailer

# General Safety Information

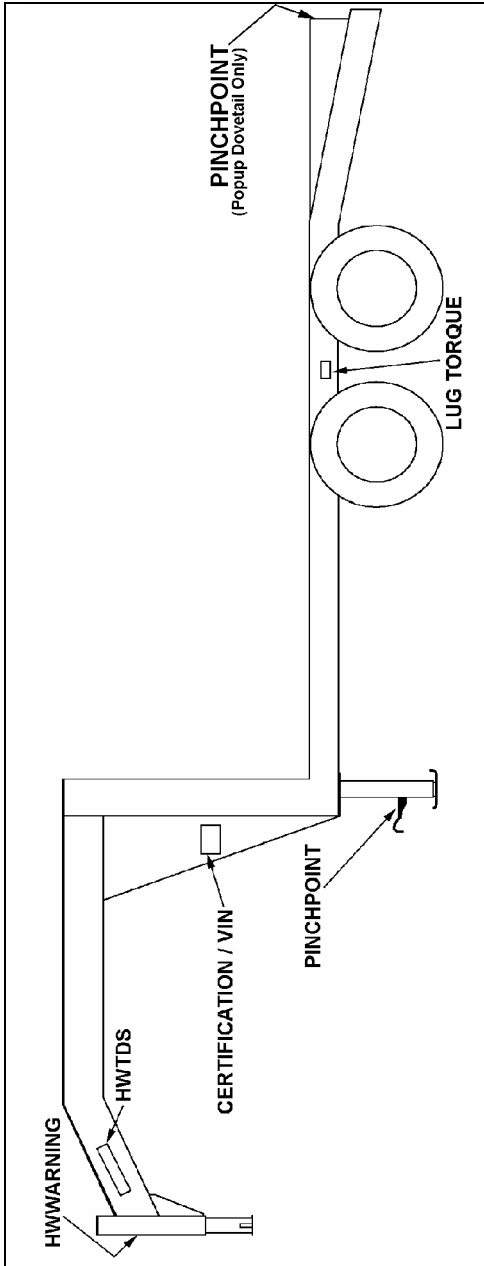

Safety Warning Labels – Gooseneck Utility Trailer

## General Safety Information

### WARNING

To protect you and others against death or serious injury, all of the labels shown must be on the trailer and must be legible.

If any of these labels are missing or cannot be read, call PJ Trailers at 800-452-9116 for free replacement labels.

You will need to provide us with the number shown at the bottom of the label(s) in order for us to send the correct one(s).

### **2.2.18 Trailer Towing Guide**

Driving a vehicle with a trailer in tow is vastly different from driving the same vehicle without a trailer in tow. Acceleration, maneuverability and braking are all diminished with a trailer in tow. It takes longer to get up to speed, you need more room to turn and pass, and more distance to stop when towing a trailer. You will need to spend time adjusting to the different feel and maneuverability of the tow vehicle with a loaded trailer. Because of the significant differences in all aspects of maneuverability when towing a trailer, the hazards and risks of injury are also much greater than when driving without a trailer. You are responsible for keeping your vehicle and trailer in control, and for all the damage that is caused if you lose control of your vehicle and trailer.

As you did when learning to drive an automobile, find an open area with little or no traffic for your first practice trailering. Of course, before you start towing the trailer, you must follow all of the instructions for inspection, testing, loading and coupling. Also, before you start towing, adjust the mirrors so you can see the trailer as well as the area to the rear of it.

Drive slowly at first, 5 mph or so, and turn the wheel to get the feel of how the tow vehicle and trailer combination responds. Next, make some right and left hand turns. Watch in your side mirrors to see how the trailer follows the tow vehicle. Turning with a trailer attached requires more room.

Stop the rig a few times from speeds no greater than 10 mph. If your trailer is equipped with brakes, try using different combinations of

## General Safety Information

trailer/electric brake and tow vehicle brake. Note the effect that the trailer brakes have when they are the only brakes used. When properly adjusted, the trailer brakes will come on just before the tow vehicle brakes.

It will take practice to learn how to back up a tow vehicle with a trailer attached. Take it slow. Before backing up, get out of the tow vehicle and look behind the trailer to make sure that there are no obstacles. Some drivers place their hands at the bottom of the steering wheel, and while the tow vehicle is in reverse, “think” of the hands as being on the top of the wheel. When the hands move to the right (counter-clockwise, as you would do to turn the tow vehicle to the left when moving forward), the rear of the trailer moves to the right. Conversely, rotating the steering wheel clockwise with your hands at the bottom of the wheel will move the rear of the trailer to the left, while backing up. If you are towing a bumper hitch rig, be careful not to allow the trailer to turn too much, because it will hit the rear of the tow vehicle. To straighten the rig, either pull forward, or turn the steering wheel in the opposite direction.

### **2.2.19 Safe Trailer Towing Guidelines**

- Recheck the load tiedowns to make sure the load will not shift during towing.
- Before towing, check coupling, safety chain, safety brake, tires, wheels and lights.
- Check the lug nuts or bolts for tightness. Refer to Section 10.2.12
- Check coupler tightness after towing 50 miles.
- Adjust the brake controller to engage the trailer brakes before the tow vehicle brakes. Follow the instructions given with the brake controller manufacturer’s literature.
- Use your mirrors to verify that you have room to change lanes or pull into traffic.
- Use your turn signals well in advance.
- Allow plenty of stopping space for your trailer and tow vehicle.
- Do not drive so fast that the trailer begins to sway due to speed. Generally never drive faster than 60 m.p.h.
- Allow plenty of room for passing. A rule of thumb is that the passing distance with a trailer is 4 times the passing distance without a trailer.

## General Safety Information

- Shift your automatic transmission into a lower gear for city driving.
- Use lower gears for climbing and descending grades.
- Do not ride the brakes while descending grades, they may get so hot that they stop working. Then you will potentially have a runaway tow vehicle and trailer.
- To conserve fuel, don't use full throttle to climb a hill. Instead, build speed on the approach.
- Slow down for bumps in the road. Take your foot off the brake when crossing the bump.
- Do not brake while in a curve unless absolutely necessary. Instead, slow down before you enter the curve.
- Do not apply the tow vehicle brakes to correct extreme trailer swaying. Instead, lightly apply the trailer brakes with the hand controller.
- Make regular stops, about once each hour. Confirm that
  - The coupler is secure to the hitch and is locked,
  - Electrical connectors are made,
  - There is appropriate slack in the safety chains,
  - There is appropriate slack in the breakaway switch pullpin cable,
  - The tires are not visibly low on pressure, and
  - The cargo is secure and in good condition.

### **2.2.20 Reporting Safety Defects**

If you believe that your vehicle has a defect that could cause a crash or could cause injury or death, you should immediately inform the National Highway Traffic Safety Administration (NHTSA) in addition to notifying us.

If NHTSA receives similar complaints, it may open an investigation, and if it finds that a safety defect exists in a group of vehicles, it may order a recall and remedy campaign. However, NHTSA cannot become involved in individual problems between you, your dealer, or us.

To contact NHTSA, you may call the Vehicle Safety Hotline toll-free at 1-888-327-4236 (TTY: 1-800-424-9153); or go to <http://www.safercar.gov>; or write to: Administrator, NHTSA, 400

## General Safety Information

Seventh Street, SW, Washington, DC 20590. You can also obtain other information about motor vehicle safety from <http://www.safercar.gov>.

Call 800-452-9116 to reach PJ Trailers.

## 3 TIRE SAFETY INFORMATION

This portion of the User’s Manual contains tire safety information as required by 49 CFR 575.6.

Section 2.1 contains “Trailer Tire Information”.

Section 2.2 contains “Steps for Determining Correct Load Limit - Trailer”.

Section 2.3 contains “Steps for Determining Correct Load Limit – Tow Vehicle”.

Section 2.4 contains a Glossary of Tire Terminology, including “cold inflation pressure”, “maximum inflation pressure”, “recommended inflation pressure”, and other non-technical terms.

Section 2.5 contains information from the NHTSA brochure entitled “Tire Safety – Everything Rides On It”.

This brochure, as well as the preceding subsections, describe the following items;

- Tire labeling, including a description and explanation of each marking on the tires, and information about the DOT Tire Identification Number (TIN).
- Recommended tire inflation pressure, including a description and explanation of:
  - A. Cold inflation pressure.
  - B. Vehicle Placard and location on the vehicle.
  - C. Adverse safety consequences of under inflation (including tire failure).
  - D. Measuring and adjusting air pressure for proper inflation.
- Tire Care, including maintenance and safety practices.
- Vehicle load limits, including a description and explanation of the following items:
  - A. Locating and understanding the load limit information, total load capacity, and cargo capacity.
  - B. Calculating total and cargo capacities with varying seating configurations including quantitative examples showing /

## Tire Safety Information

illustrating how the vehicles cargo and luggage capacity decreases as combined number and size of occupants' increases. This item is also discussed in Section 3.

- C. Determining compatibility of tire and vehicle load capabilities.
- D. Adverse safety consequences of overloading on handling and stopping on tires.

### **3.1 TRAILER TIRE INFORMATION**

Trailer tires may be worn out even though they still have plenty of tread left. This is because trailer tires have to carry a lot of weight all the time, even when not in use. It is actually better for the tire to be rolling down the road than to be idle. During use, the tire releases lubricants that are beneficial to tire life. Using the trailer tires often also helps prevent flat spots from developing.

The main cause of tire failure is improper inflation. Check the cold tire inflation pressures at least once a week for proper inflation levels. "Cold" means that the tires are at the same temperature as the surrounding air, such as when the vehicle has been parked overnight. Wheel and tire manufacturers recommend adjusting the air pressure to the trailer manufacturer's recommended cold inflation pressure, in pounds per square inch (PSI) stated on the vehicle's Federal Certification Label or Tire Placard when the trailer is loaded to its gross vehicle weight rating (GVWR). If the tires are inflated to less than the recommended inflation level or the GVWR of the trailer is exceeded, the load carrying capacity of the tire could be dramatically affected. If the tires are inflated more than the recommended inflation level, handling characteristics of the tow vehicle/trailer combination could be affected. Refer to the owner's manual or talk to your dealer or vehicle manufacturer if you have any questions regarding proper inflation practices.

Tires can lose air over a period of time. In fact, tires can lose 1 to 3 PSI per month. This is because molecules of air, under pressure, weave their way from the inside of the tire, through the rubber, to the outside. A drop in tire pressure could cause the tire to become overloaded, leading to excessive heat build up. If a trailer tire is under-inflated, even for a short period of time, the tire could suffer internal damage.

## Tire Safety Information

High speed towing in hot conditions degrades trailer tires significantly. As heat builds up during driving, the tire's internal structure starts to breakdown, compromising the strength of the tire. It is recommended to drive at moderate speeds.

Statistics indicate the average life of a trailer tire is about five years under normal use and maintenance conditions. After three years, replacing the trailer tires with new ones should be considered, even if the tires have adequate tread depth. Some experts claim that after five years, trailer tires are considered worn out and should be replaced, even if they have had minimal or no use. This is such a general statement that it may not apply in all cases. It is best to have your tires inspected by a tire supplier to determine if your tires need to be replaced.

If you are storing your trailer for an extended period, make sure the tires are fully inflated to the maximum rated pressure and that you store them in a cool, dry place, such as a garage. Use tire covers to protect the trailer tires from the harsh effects of the sun.

### **3.2 STEPS FOR DETERMINING CORRECT LOAD LIMIT – TRAILER**

Determining the load limits of a trailer includes more than understanding the load limits of the tires alone. On all trailers there is a Federal Certification / VIN label that is located on the forward half of the left (road) side of the unit. This certification/VIN label will indicate the trailer's Gross Vehicle Weight Rating (GVWR). This is the most weight the fully loaded trailer can weigh. It will also provide the Gross Axle Weight Rating (GAWR). This is the most a particular axle can weigh. If there are multiple axles, the GAWR of each axle will be provided.

If your trailer has a GVWR of 10,000 pounds or less, there is a vehicle placard located in the same location as the certification label described above. This placard provides tire and loading information. In addition, this placard will show a statement regarding maximum cargo capacity. Cargo can be added to the trailer, up to the maximum weight specified on the placard. The combined weight of the cargo is provided as a single number. In any case, remember: the total weight of a fully loaded trailer can not exceed the stated GVWR.

## Tire Safety Information

When loading your cargo, be sure it is distributed evenly to prevent overloading front to back and side to side. Heavy items should be placed low and as close to the axle positions as reasonable. Too many items on one side may overload a tire. The best way to know the actual weight of the vehicle is to weigh it at a public scale. Talk to your dealer to discuss the weighing methods needed to capture the various weights related to the trailer. This would include the weight empty or unloaded, weights per axle, wheel, hitch or king-pin, and total weight.

Excessive loads and/or underinflation cause tire overloading and, as a result, abnormal tire flexing occurs. This situation can generate an excessive amount of heat within the tire. Excessive heat may lead to tire failure. It is the air pressure that enables a tire to support the load, so proper inflation is critical. The proper air pressure may be found on the Certification / VIN label and/or on the Tire Placard. This value should never exceed the maximum cold inflation pressure stamped on the tire.

### 3.2.1 Trailers 10,000 Pounds GVWR or Less

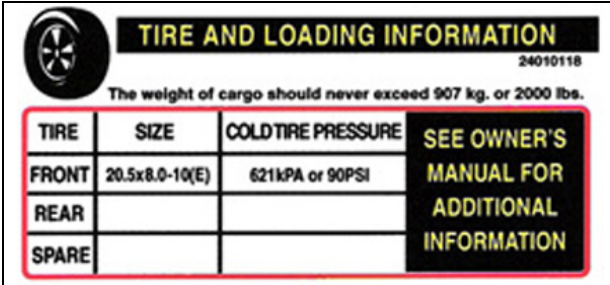

The placard features a tire icon on the left, a title bar with the text 'TIRE AND LOADING INFORMATION' and the number '24010118', and a warning statement: 'The weight of cargo should never exceed 907 kg. or 2000 lbs.' Below this is a table with columns for 'TIRE', 'SIZE', and 'COLD TIRE PRESSURE'. The 'FRONT' row is filled with '20.5x8.0-10(E)' and '621kPA or 90PSI'. The 'REAR' and 'SPARE' rows are empty. To the right of the table is a box with the text 'SEE OWNER'S MANUAL FOR ADDITIONAL INFORMATION'.

TIRE	SIZE	COLD TIRE PRESSURE	SEE OWNER'S MANUAL FOR ADDITIONAL INFORMATION
FRONT	20.5x8.0-10(E)	621kPA or 90PSI	
REAR			
SPARE			

Tire Information Placard – Figure 3-1

8. Locate the statement, “The weight of cargo should never exceed XXX kg or XXX lbs.,” on your vehicle’s placard. See figure 3-1.
9. This figure equals the available amount of cargo and luggage load capacity.
10. Determine the combined weight of luggage and cargo being loaded on the vehicle. That weight may not safely exceed the available cargo and luggage load capacity.
11. The trailer’s placard refers to the Tire Information Placard attached adjacent to or near the trailer’s VIN (Certification) label at the left front of the trailer.

# Tire Safety Information

## **3.2.2 Trailers Over 10,000 Pounds GVWR**

**(Note: These trailers are not required to have a tire information placard on the trailer and may not have one installed)**

1. Determine the empty weight of your trailer by weighing the trailer using a public scale or other means.
2. Locate the GVWR (Gross Vehicle Weight Rating) of the trailer on your trailer's VIN (Certification) label.
3. Subtract the empty weight of your trailer from the GVWR stated on the VIN label. That weight is the maximum available cargo capacity of the trailer and may not be safely exceeded.

## **3.3 STEPS FOR DETERMINING CORRECT LOAD LIMIT – TOW VEHICLE**

1. Locate the statement, "The combined weight of occupants and cargo should never exceed XXX lbs.," on your vehicle's placard.
2. Determine the combined weight of the driver and passengers who will be riding in your vehicle.
3. Subtract the combined weight of the driver and passengers from XXX kilograms or XXX pounds.
4. The resulting figure equals the available amount of cargo and luggage capacity. For example, if the "XXX" amount equals 1400 lbs. and there will be five 150 lb. passengers in your vehicle, the amount of available cargo and luggage capacity is 650 lbs. ( $1400 - 750 (5 \times 150) = 650$  lbs.).
5. Determine the combined weight of luggage and cargo being loaded on the vehicle. That weight may not safely exceed the available cargo and luggage capacity calculated in Step # 4.
6. If your vehicle will be towing a trailer, load from your trailer will be transferred to your vehicle. Consult the tow vehicle's manual to determine how this weight transfer reduces the available cargo and luggage capacity of your vehicle.

## **3.4 GLOSSARY OF TIRE TERMINOLOGY**

**Accessory weight** The combined weight (in excess of those standard items which may be replaced) of automatic transmission, power steering, power brakes, power windows, power seats, radio and heater, to the

## Tire Safety Information

extent that these items are available as factory-installed equipment (whether installed or not).

**Bead** The part of the tire that is made of steel wires, wrapped or reinforced by ply cords and that is shaped to fit the rim.

**Bead separation** This is the breakdown of the bond between components in the bead.

**Bias ply tire** A pneumatic tire in which the ply cords that extend to the beads are laid at alternate angles substantially less than 90 degrees to the centerline of the tread.

**Carcass** The tire structure, except tread and sidewall rubber which, when inflated, bears the load.

**Chunking** The breaking away of pieces of the tread or sidewall.

**Cold inflation pressure** The pressure in the tire before you drive.

**Cord** The strands forming the plies in the tire.

**Cord separation** The parting of cords from adjacent rubber compounds.

**Cracking** Any parting within the tread, sidewall, or inner liner of the tire extending to cord material.

**CT** A pneumatic tire with an inverted flange tire and rim system in which the rim is designed with rim flanges pointed radially inward and the tire is designed to fit on the underside of the rim in a manner that encloses the rim flanges inside the air cavity of the tire.

**Curb weight** The weight of a motor vehicle with standard equipment including the maximum capacity of fuel, oil, and coolant, and, if so equipped, air conditioning and additional weight optional engine.

**Extra load tire** A tire designed to operate at higher loads and at higher inflation pressures than the corresponding standard tire.

## Tire Safety Information

**Groove** The space between two adjacent tread ribs.

**Gross Axle Weight Rating** The maximum weight that any axle can support, as published on the Certification / VIN label on the front left side of the trailer. Actual weight determined by weighing each axle on a public scale, with the trailer attached to the towing vehicle.

**Gross Vehicle Weight Rating** The maximum weight of the fully loaded trailer, as published on the Certification / VIN label. Actual weight determined by weighing trailer on a public scale, without being attached to the towing vehicle.

**Hitch Weight** The downward force exerted on the hitch ball by the trailer coupler.

**Innerliner** The layer(s) forming the inside surface of a tubeless tire that contains the inflating medium within the tire.

**Innerliner separation** The parting of the innerliner from cord material in the carcass.

**Intended outboard sidewall** The sidewall that contains a white-wall, bears white lettering or bears manufacturer, brand, and/or model name molding that is higher or deeper than the same molding on the other sidewall of the tire or the outward facing sidewall of an asymmetrical tire that has a particular side that must always face outward when mounted on a vehicle.

**Light truck (LT) tire** A tire designated by its manufacturer as primarily intended for use on lightweight trucks or multipurpose passenger vehicles. May be used on trailers.

**Load rating** The maximum load that a tire is rated to carry for a given inflation pressure.

**Maximum load rating** The load rating for a tire at the maximum permissible inflation pressure for that tire.

## Tire Safety Information

**Maximum permissible inflation pressure** The maximum cold inflation pressure to which a tire may be inflated.

**Maximum loaded vehicle weight** The sum of curb weight, accessory weight, vehicle capacity weight, and production options weight.

**Measuring rim** The rim on which a tire is fitted for physical dimension requirements.

**Non-pneumatic rim** A mechanical device which, when a non-pneumatic tire assembly incorporates a wheel, supports the tire, and attaches, either integrally or separably, to the wheel center member and upon which the tire is attached.

**Non-pneumatic spare tire assembly** A non-pneumatic tire assembly intended for temporary use in place of one of the pneumatic tires and rims that are fitted to a passenger car in compliance with the requirements of this standard.

**Non-pneumatic tire** A mechanical device which transmits, either directly or through a wheel or wheel center member, the vertical load and tractive forces from the roadway to the vehicle, generates the tractive forces that provide the directional control of the vehicle and does not rely on the containment of any gas or fluid for providing those functions.

**Non-pneumatic tire assembly** A non-pneumatic tire, alone or in combination with a wheel or wheel center member, which can be mounted on a vehicle.

**Normal occupant weight** This means 68 kilograms (150 lbs.) times the number of occupants specified in the second column of Table I of 49 CFR 571.110.

**Occupant distribution** The distribution of occupants in a vehicle as specified in the third column of Table I of 49 CFR 571.110.

**Open splice** Any parting at any junction of tread, sidewall, or innerliner that extends to cord material.

## Tire Safety Information

**Outer diameter** The overall diameter of an inflated new tire.

**Overall width** The linear distance between the exteriors of the sidewalls of an inflated tire, including elevations due to labeling, decorations, or protective bands or ribs.

**Pin Weight** The downward force applied to the 5<sup>th</sup> wheel or gooseneck ball, by the trailer kingpin or gooseneck coupler.

**Ply** A layer of rubber-coated parallel cords.

**Ply separation** A parting of rubber compound between adjacent plies.

**Pneumatic tire** A mechanical device made of rubber, chemicals, fabric and steel or other materials, that, when mounted on an automotive wheel, provides the traction and contains the gas or fluid that sustains the load.

**Production options weight** The combined weight of those installed regular production options weighing over 2.3 kilograms (5 lbs.) in excess of those standard items which they replace, not previously considered in curb weight or accessory weight, including heavy duty brakes, ride levelers, roof rack, heavy duty battery, and special trim.

**Radial ply tire** A pneumatic tire in which the ply cords that extend to the beads are laid at substantially 90 degrees to the centerline of the tread.

**Recommended inflation pressure** This is the inflation pressure provided by the vehicle manufacturer on the Tire Information label and on the Certification / VIN tag.

**Reinforced tire** A tire designed to operate at higher loads and at higher inflation pressures than the corresponding standard tire.

**Rim** A metal support for a tire or a tire and tube assembly upon which the tire beads are seated.

**Rim diameter** This means the nominal diameter of the bead seat.

## Tire Safety Information

**Rim size designation** This means the rim diameter and width.

**Rim type designation** This means the industry of manufacturer's designation for a rim by style or code.

**Rim width** This means the nominal distance between rim flanges.

**Section width** The linear distance between the exteriors of the sidewalls of an inflated tire, excluding elevations due to labeling, decoration, or protective bands.

**Sidewall** That portion of a tire between the tread and bead.

**Sidewall separation** The parting of the rubber compound from the cord material in the sidewall.

**Special Trailer (ST) tire** The "ST" is an indication the tire is for trailer use only.

**Test rim** The rim on which a tire is fitted for testing, and may be any rim listed as appropriate for use with that tire.

**Tread** That portion of a tire that comes into contact with the road.

**Tread rib** A tread section running circumferentially around a tire.

**Tread separation** Pulling away of the tread from the tire carcass.

**Treadwear indicators (TWI)** The projections within the principal grooves designed to give a visual indication of the degrees of wear of the tread.

**Vehicle capacity weight** The rated cargo and luggage load plus 68 kilograms (150 lbs.) times the vehicle's designated seating capacity.

**Vehicle maximum load on the tire** The load on an individual tire that is determined by distributing to each axle its share of the maximum loaded vehicle weight and dividing by two.

## Tire Safety Information

**Vehicle normal load on the tire** The load on an individual tire that is determined by distributing to each axle its share of the curb weight, accessory weight, and normal occupant weight (distributed in accordance with Table I of CRF 49 571.110) and dividing by 2.

**Weather side** The surface area of the rim not covered by the inflated tire.

**Wheel center member** In the case of a non-pneumatic tire assembly incorporating a wheel, a mechanical device which attaches, either integrally or separably, to the non-pneumatic rim and provides the connection between the non-pneumatic rim and the vehicle; or, in the case of a non-pneumatic tire assembly not incorporating a wheel, a mechanical device which attaches, either integrally or separably, to the non-pneumatic tire and provides the connection between tire and the vehicle.

**Wheel-holding fixture** The fixture used to hold the wheel and tire assembly securely during testing.

### **3.5 TIRE SAFETY - EVERYTHING RIDES ON IT**

The National Traffic Safety Administration (NHTSA) has published a brochure (DOT HS 809 361) that discusses all aspects of Tire Safety, as required by CFR 575.6. This brochure is reproduced in part below. It can be obtained and downloaded from NHTSA, free of charge, from the following web site:

[http://www.nhtsa.dot.gov/cars/rules/TireSafety/ridesonit/tires\\_index.html](http://www.nhtsa.dot.gov/cars/rules/TireSafety/ridesonit/tires_index.html)

Studies of tire safety show that maintaining proper tire pressure, observing tire and vehicle load limits (not carrying more weight in your vehicle than your tires or vehicle can safely handle), avoiding road hazards, and inspecting tires for cuts, slashes, and other irregularities are the most important things you can do to avoid tire failure, such as tread separation or blowout and flat tires. These actions, along with other care and maintenance activities, can also:

- Improve vehicle handling

# Tire Safety Information

- Help protect you and others from avoidable breakdowns and accidents
- Improve fuel economy
- Increase the life of your tires.

This booklet presents a comprehensive overview of tire safety, including information on the following topics:

- Basic tire maintenance
- Uniform Tire Quality Grading System
- Fundamental characteristics of tires
- Tire safety tips.

Use this information to make tire safety a regular part of your vehicle maintenance routine. Recognize that the time you spend is minimal compared with the inconvenience and safety consequences of a flat tire or other tire failure.

## **3.5.1 Safety First—Basic Tire Maintenance**

Properly maintained tires improve the steering, stopping, traction, and load-carrying capability of your vehicle. Underinflated tires and overloaded vehicles are a major cause of tire failure. Therefore, as mentioned above, to avoid flat tires and other types of tire failure, you should maintain proper tire pressure, observe tire and vehicle load limits, avoid road hazards, and regularly inspect your tires.

## **3.5.2 Finding Your Vehicle's Recommended Tire Pressure and Load Limits**

Tire information placards and vehicle certification labels contain information on tires and load limits. These labels indicate the vehicle manufacturer's information including:

- Recommended tire size
- Recommended tire inflation pressure
- Vehicle capacity weight (VCW—the maximum occupant and cargo weight a vehicle is designed to carry)
- Front and rear gross axle weight ratings (GAWR— the maximum weight the axle systems are designed to carry).

## Tire Safety Information

Both placards and certification labels are permanently attached to the trailer near the left front.

### **3.5.3 Understanding Tire Pressure and Load Limits**

Tire inflation pressure is the level of air in the tire that provides it with load-carrying capacity and affects the overall performance of the vehicle. The tire inflation pressure is a number that indicates the amount of air pressure—measured in pounds per square inch (psi)—a tire requires to be properly inflated. (You will also find this number on the vehicle information placard expressed in kilopascals (kPa), which is the metric measure used internationally.)

Manufacturers of passenger vehicles and light trucks determine this number based on the vehicle's design load limit, that is, the greatest amount of weight a vehicle can safely carry and the vehicle's tire size. The proper tire pressure for your vehicle is referred to as the "recommended cold inflation pressure." (As you will read below, it is difficult to obtain the recommended tire pressure if your tires are not cold.)

Because tires are designed to be used on more than one type of vehicle, tire manufacturers list the "maximum permissible inflation pressure" on the tire sidewall. This number is the greatest amount of air pressure that should ever be put in the tire under normal driving conditions.

### **3.5.4 Checking Tire Pressure**

It is important to check your vehicle's tire pressure at least once a month for the following reasons:

- Most tires may naturally lose air over time.
- Tires can lose air suddenly if you drive over a pothole or other object or if you strike the curb when parking.
- With radial tires, it is usually not possible to determine underinflation by visual inspection.

For convenience, purchase a tire pressure gauge to keep in your vehicle. Gauges can be purchased at tire dealerships, auto supply stores, and other retail outlets.

The recommended tire inflation pressure that vehicle manufacturers provide reflects the proper psi when a tire is cold. The term cold does not

## Tire Safety Information

relate to the outside temperature. Rather, a cold tire is one that has not been driven on for at least three hours. When you drive, your tires get warmer, causing the air pressure within them to increase. Therefore, to get an accurate tire pressure reading, you must measure tire pressure when the tires are cold or compensate for the extra pressure in warm tires.

### **3.5.5 Steps for Maintaining Proper Tire Pressure**

- Step 1: Locate the recommended tire pressure on the vehicle's tire information placard, certification label, or in the owner's manual.
- Step 2: Record the tire pressure of all tires.
- Step 3: If the tire pressure is too high in any of the tires, slowly release air by gently pressing on the tire valve stem with the edge of your tire gauge until you get to the correct pressure.
- Step 4: If the tire pressure is too low, note the difference between the measured tire pressure and the correct tire pressure. These "missing" pounds of pressure are what you will need to add.
- Step 5: At a service station, add the missing pounds of air pressure to each tire that is underinflated.
- Step 6: Check all the tires to make sure they have the same air pressure (except in cases in which the front and rear tires are supposed to have different amounts of pressure).

If you have been driving your vehicle and think that a tire is underinflated, fill it to the recommended cold inflation pressure indicated on your vehicle's tire information placard or certification label. While your tire may still be slightly underinflated due to the extra pounds of pressure in the warm tire, it is safer to drive with air pressure that is slightly lower than the vehicle manufacturer's recommended cold inflation pressure than to drive with a significantly underinflated tire. Since this is a temporary fix, don't forget to recheck and adjust the tire's pressure when you can obtain a cold reading.

### **3.5.6 Tire Size**

To maintain tire safety, purchase new tires that are the same size as the vehicle's original tires or another size recommended by the manufacturer. Look at the tire information placard, the owner's manual, or the sidewall

## Tire Safety Information

of the tire you are replacing to find this information. If you have any doubt about the correct size to choose, consult with the tire dealer.

### **3.5.7 Tire Tread**

The tire tread provides the gripping action and traction that prevent your vehicle from slipping or sliding, especially when the road is wet or icy. In general, tires are not safe and should be replaced when the tread is worn down to 2/32 of an inch. Tires have built-in treadwear indicators that let you know when it is time to replace your tires. These indicators are raised sections spaced intermittently in the bottom of the tread grooves. When they appear "even" with the outside of the tread, it is time to replace your tires. Another method for checking tread depth is to place a penny in the tread with Lincoln's head upside down and facing you. If you can see the top of Lincoln's head, you are ready for new tires.

### **3.5.8 Tire Balance and Wheel Alignment**

To avoid vibration or shaking of the vehicle when a tire rotates, the tire must be properly balanced. This balance is achieved by positioning weights on the wheel to counterbalance heavy spots on the wheel-and-tire assembly. A wheel alignment adjusts the angles of the wheels so that they are positioned correctly relative to the vehicle's frame. This adjustment maximizes the life of your tires. These adjustments require special equipment and should be performed by a qualified technician.

### **3.5.9 Tire Repair**

The proper repair of a punctured tire requires a plug for the hole and a patch for the area inside the tire that surrounds the puncture hole. Punctures through the tread can be repaired if they are not too large, but punctures to the sidewall should not be repaired. Tires must be removed from the rim to be properly inspected before being plugged and patched.

### **3.5.10 Tire Fundamentals**

Federal law requires tire manufacturers to place standardized information on the sidewall of all tires. This information identifies and describes the fundamental characteristics of the tire and also provides a tire identification number for safety standard certification and in case of a recall.

# Tire Safety Information

## 3.5.10.1 Information on Passenger Vehicle Tires

Please refer to the diagram below.

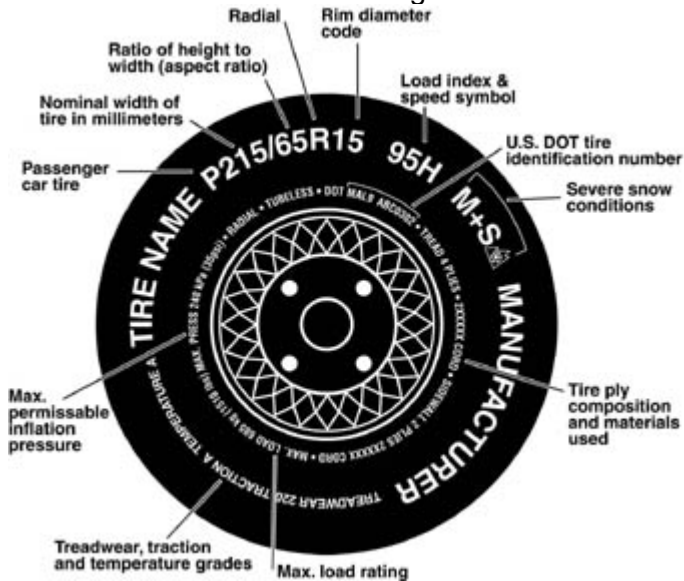

### P

The "P" indicates the tire is for passenger vehicles.

### Next number

This three-digit number gives the width in millimeters of the tire from sidewall edge to sidewall edge. In general, the larger the number, the wider the tire.

### Next number

This two-digit number, known as the aspect ratio, gives the tire's ratio of height to width. Numbers of 70 or lower indicate a short sidewall for improved steering response and better overall handling on dry pavement.

### R

The "R" stands for radial. Radial ply construction of tires has been the industry standard for the past 20 years.

### Next number

This two-digit number is the wheel or rim diameter in inches. If you

## Tire Safety Information

change your wheel size, you will have to purchase new tires to match the new wheel diameter.

### Next number

This two- or three-digit number is the tire's load index. It is a measurement of how much weight each tire can support. You may find this information in your owner's manual. If not, contact a local tire dealer. Note: You may not find this information on all tires because it is not required by law.

### M+S

The "M+S" or "M/S" indicates that the tire has some mud and snow capability. Most radial tires have these markings; hence, they have some mud and snow capability.

### Speed Rating

The speed rating denotes the speed at which a tire is designed to be driven for extended periods of time. The ratings range from 99 miles per hour (mph) to 186 mph. These ratings are listed below. Note: You may not find this information on all tires because it is not required by law.

Letter Rating	Speed Rating
Q	99 mph
R	106 mph
S	112 mph
T	118 mph
U	124 mph
H	130 mph
V	149 mph
W	168* mph
Y	186* mph

\* For tires with a maximum speed capability over 149 mph, tire manufacturers sometimes use the letters ZR. For those with a maximum speed capability over 186 mph, tire manufacturers always use the letters ZR.

# Tire Safety Information

## **U.S. DOT Tire Identification Number**

This begins with the letters "DOT" and indicates that the tire meets all federal standards. The next two numbers or letters are the plant code where it was manufactured, and the last four numbers represent the week and year the tire was built. For example, the numbers 3197 means the 31st week of 1997. The other numbers are marketing codes used at the manufacturer's discretion. This information is used to contact consumers if a tire defect requires a recall.

## **Tire Ply Composition and Materials Used**

The number of plies indicates the number of layers of rubber-coated fabric in the tire. In general, the greater the number of plies, the more weight a tire can support. Tire manufacturers also must indicate the materials in the tire, which include steel, nylon, polyester, and others.

## **Maximum Load Rating**

This number indicates the maximum load in kilograms and pounds that can be carried by the tire.

## **Maximum Permissible Inflation Pressure**

This number is the greatest amount of air pressure that should ever be put in the tire under normal driving conditions.

### **3.5.10.2 UTQGS Information**

#### **Treadwear Number**

This number indicates the tire's wear rate. The higher the treadwear number is, the longer it should take for the tread to wear down. For example, a tire graded 400 should last twice as long as a tire graded 200.

#### **Traction Letter**

This letter indicates a tire's ability to stop on wet pavement. A higher graded tire should allow you to stop your car on wet roads in a shorter distance than a tire with a lower grade. Traction is graded from highest to lowest as "AA", "A", "B", and "C".

#### **Temperature Letter**

This letter indicates a tire's resistance to heat. The temperature grade is for a tire that is inflated properly and not overloaded. Excessive speed, underinflation or excessive loading, either separately or in combination,



## Tire Safety Information

This information indicates the maximum load and tire pressure when the tire is used as a single.

### **Load Range**

This information identifies the tire's load-carrying capabilities and its inflation limits.

### **3.5.11 Tire Safety Tips**

#### **Preventing Tire Damage**

- Slow down if you have to go over a pothole or other object in the road.
- Do not run over curbs or other foreign objects in the roadway, and try not to strike the curb when parking.

#### **Tire Safety Checklist**

- Check tire pressure regularly (at least once a month), including the spare.
- Inspect tires for uneven wear patterns on the tread, cracks, foreign objects, or other signs of wear or trauma.
- Remove bits of glass and foreign objects wedged in the tread.
- Make sure your tire valves have valve caps.
- Check tire pressure before going on a long trip.
- Do not overload your vehicle. Check the Tire Information Placard or Owner's Manual for the maximum recommended load for the vehicle.

## 4 COUPLING TO THE TOW VEHICLE

Follow all of the safety precautions and instructions in this manual to ensure safety of persons, cargo, and satisfactory life of the trailer.

### 4.1 USE AN ADEQUATE TOW VEHICLE AND HITCH

If the vehicle or hitch is not properly selected and matched to the Gross Vehicle Weight Rating (GVWR) of your trailer, you can cause an accident that could lead to death or serious injury. If you already have a tow vehicle, know your vehicle tow rating and make certain the trailer's rated capacity is less than or equal to the tow vehicle's rated towing capacity.

#### **Danger**

Use of a hitch with a load rating less than the load rating of the trailer can result in loss of control and may lead to death or serious injury.

Use of a tow vehicle with a towing capacity less than the load rating of the trailer can result in loss of control, and may lead to death or serious injury.

Be sure your hitch and tow vehicle are rated for the Gross Vehicle Weight Rating of your trailer.

#### 4.1.1 Trailer Information

The Certification / Vehicle Identification Number (VIN) tag is located on the front left corner of your trailer.

The trailer Certification / VIN tag contains the following critical safety information for the use of your trailer:

**MANUFACTURER:** Name of trailer manufacturer

**DATE OF MANUFACTURE:** Month and year the trailer was manufactured.

## Coupling To The Tow Vehicle

**GAWR:** The Gross Vehicle Weight Rating is the maximum allowable gross weight of the trailer and its contents. The gross weight of the trailer includes the weight of the trailer and all of the items within it (such as cargo, water, food and other supplies). GVWR is sometimes referred to as GTW (Gross Trailer Weight), or MGTW (Maximum Gross Trailer Weight). GVWR, GTW and MGTW are all the same rating.

**GAWR:** The Gross Axle Weight Rating is the maximum gross weight that an axle can support. It is the lowest of axle, wheel, or tire rating. Sometimes the tire or wheel rating is lower than the axle manufacturers rating, and will then determine GAWR.

The sum total of the GAWR for all trailer axles may be less than the GVWR for the trailer, because some of the trailer load is carried by the tow vehicle, rather than by the trailer axle(s). The total weight of the cargo and trailer must not exceed the GVWR, and the load on an axle must not exceed its GAWR.

**TIRE SIZE:** The tire size recommended for your trailer and load range.

**PSIC:** The “pounds per square inch- cold” is the tire pressure (Kilopascals / Pounds per Square Inch) measured when Cold.

**VIN:** The Vehicle Identification Number.

**VEHICLE TYPE:** Generally the word “trailer” is used. However, after this you may put a Model #, or additional descriptor.

**CERTIFICATION STATEMENT:** “This trailer meets all the Federal Motor Vehicle Safety Standards in effect on the date of manufacture shown above”.

**VIN:** The Vehicle Identification Number.

**VEHICLE TYPE:** The word “trailer” is used, followed by a Model #, or additional descriptor.

## Coupling To The Tow Vehicle

### 4.1.2 Tow Vehicle

When equipping a new vehicle or an older vehicle to tow your trailer, ask the vehicle dealer for advice on how to outfit the towing vehicle. Discuss the following information and equipment with the vehicle dealer.

**Overall Carrying and Towing Capacity of Vehicle:** Vehicle manufacturers will provide you with the maximum towing capacities of their various models, as well as the GCWR. No amount of reinforcement will give a 100 horsepower, 2,500 pound truck the towing capacity that a 300 horsepower, 5,000 pound truck has.

**Towing Hitch:** The towing hitch attached to your tow vehicle must have a capacity equal to or greater than the load rating of the trailer you intend to tow. The hitch capacity must also be matched to the tow vehicle capacity.

**Suspension System:** A tow vehicle equipped with a factory installed “Towing Package” likely comes equipped with heavy duty springs, heavy duty tires and other suspension components which are able to serve the size and weight of the trailer that the vehicle is rated to tow. However, the addition of additional equipment may further improve the tow vehicle performance. These may include adjustable air shocks, helper springs, etc.

**Brake Controller:** The brake controller is part of the tow vehicle and is essential in the operation of the electric brakes on the trailer. If your trailer has electric brakes it requires a brake controller be installed at the driver’s position. The brake controller is not the same as the safety breakaway brake system that is installed on the trailer.

**Side View Mirrors:** The size of the trailer that is being towed and your state law regulations determine the size of the mirrors. However, some states prohibit extended mirrors on a tow vehicle, except while a trailer is actually being towed. In this situation, detachable extended mirrors are necessary. Check with your dealer or the appropriate state agency for mirror requirements.

## Coupling To The Tow Vehicle

**Heavy Duty Flasher:** A Heavy Duty Flasher is an electrical component that may be required when your trailer turn signal lights are attached to the tow vehicle flasher circuit.

**Electrical Connector:** An Electrical Connector connects the light and brake systems on the trailer to the light and brake controls on the towing vehicle.

**Heavy Duty Engine Oil Cooling System:** The tow vehicle engine works harder when a trailer is being towed. Depending on the size of the trailer, you may need to install a separate engine oil cooler. Inadequate cooling may result in sudden engine failure. Ask the tow vehicle dealer if it is necessary to install a heavy duty cooling system.

**Automatic Transmission Oil Cooler:** The automatic transmission of a towing vehicle handles more power when a trailer is being towed. Inadequate cooling will shorten transmission life, and may result in sudden transmission failure. Ask the tow vehicle dealer if it is necessary to install a separate oil cooler for the automatic transmission.

**Fire Extinguisher:** It is sensible to have a fire extinguisher in the tow vehicle.

**Emergency Flares and Emergency Triangle Reflectors:** It is wise to carry these warning devices even if you are not towing a trailer. It is particularly important to have these when towing a trailer because the hazard flashers of your towing vehicle will not operate for as long a period of time when the battery is running both the trailer lights and tow vehicle lights.

### **4.2 COUPLING AND UNCOUPLING THE TRAILER**

A secure coupling (or fastening) of the trailer to the tow vehicle is essential. A loss of coupling may result in death or serious injury. Therefore, you must understand and follow all of the instructions for coupling.

The following parts are involved in making a secure coupling between the trailer and tow vehicle:

## Coupling To The Tow Vehicle

**Coupling:** That part of the trailer connecting mechanism by which the connection is actually made to the trailer hitch. This does not include any structural member, extension of the trailer frame, or brake controller.

**Hitch:** That part of the connecting mechanism including the ball support platform and ball and those components that extend and are attached to the towing vehicle, including bumpers intended to serve as hitches.

**Safety chains:** Chains permanently attached to the trailer such that if the coupler connection comes loose, the safety chains can keep the trailer attached to the tow vehicle. With properly rigged safety chains, it is possible to keep the tongue of the trailer from digging into the road pavement, even if the coupler-to-hitch connection comes apart.

**Trailer lighting (and braking) connector:** A device that connects electrical power from the tow vehicle to the trailer. Electricity is used to turn on brake lights, running lights, and turn signals as required. In addition, if your trailer has a separate braking system, the electrical connector will also supply power to the trailer brakes from the tow vehicle.

**Breakaway switch:** If the trailer becomes de-coupled from the towing vehicle, the breakaway switch lanyard, attached independently to the tow vehicle hitch, will pull a pin in the emergency electrical breakaway switch on the trailer. The breakaway switch is activated by a separate battery supply in the trailer such as to energize the trailer brakes independently of the towing vehicle. It is important to check the state of charge of the emergency breakaway battery before each trip. Simply pull the pin out of the switch by hand and then try to pull the trailer. If you feel a significant drag force the brakes are activated. Be sure to re-insert the pin in the breakaway switch. Also be sure to allow enough slack in the breakaway brake lanyard such that the switch will only activate (pin pulls out) if the coupler connection comes loose.

**Jack:** A device on the trailer that is used to raise and lower the trailer tongue. On larger trailers the jack is sometimes called the “landing gear.”

## Coupling To The Tow Vehicle

### WARNING

An improperly coupled trailer can result in death or serious injury.

Do not move the trailer until:

- The coupler is secured and locked to hitch;
- The safety chains are secured to the tow vehicle; and
- The trailer jack(s) are fully retracted.

Do not tow the trailer on the road until:

- Tires and wheels are checked;
- The trailer brakes are checked;
- The breakaway switch is connected to the tow vehicle;
- The load is secured to the trailer; and
- The trailer lights are connected and checked.

#### **4.2.1 Various Coupler Designs**

Trailers are produced with a variety of coupler devices. One of the sections below will pertain to your trailer.

- Bumper pull ball coupler or ring coupler
- Gooseneck ball coupler
- Gooseneck fifth wheel or king pin coupler

If the coupler on your trailer does not resemble one of the couplers shown in the figures, see the separate coupler instructions. If you do not have separate coupler instructions, call PJ Trailers at 800-452-9116 for a free copy.

#### **4.3 BUMPER PULL TRAILERS**

##### **4.3.1 Trailer with Ball Hitch Coupler**

A ball hitch coupler connects to a ball that is located on or under the rear bumper of tow vehicle. This system of coupling a trailer to a tow vehicle is sometimes referred to as “bumper pull.”

## Coupling To The Tow Vehicle

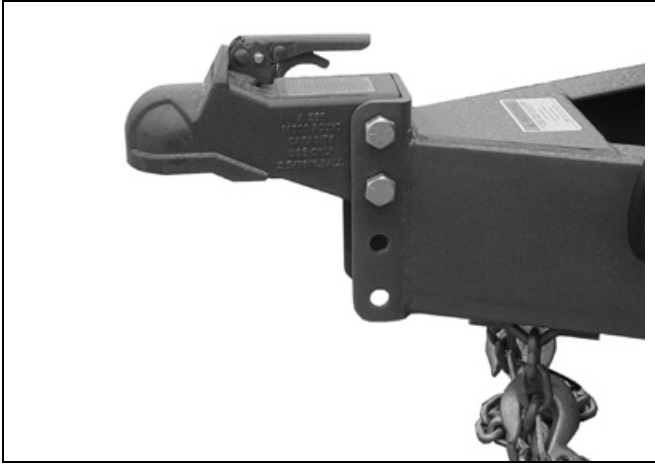

Trailer With Ball Hitch Coupler - Figure 4-1

We have utilized a ball hitch coupler that is suitable for the size and weight of the trailer. See figure 4-1. The load rating of the coupler and the necessary ball size are listed on the trailer tongue. You must provide a hitch and ball for your tow vehicle, where the load rating of the hitch and ball is equal to or greater than that of your trailer. Also, the ball size must be the same as the coupler size. If the hitch ball is too small, too large, is underrated, is loose or is worn, the trailer can come loose from the tow vehicle, and may cause death or serious injury.

**THE TOW VEHICLE, HITCH AND BALL MUST HAVE A RATED TOWING CAPACITY EQUAL TO OR GREATER THAN THE TRAILER Gross Vehicle Weight Rating (GVWR).**

**IT IS ESSENTIAL THAT THE HITCH BALL BE OF THE SAME SIZE AS THE COUPLER.**

The ball size and load rating (capacity) are marked on the ball; hitch capacity is marked on the hitch.

### **4.3.1.1 Before Coupling The Trailer To The Tow Vehicle**

Be sure the size and rating of hitch ball match the size and rating of the coupler. Hitch balls and couplers are marked with their size and rating.

## Coupling To The Tow Vehicle

### WARNING

Coupler-to-hitch mismatch can result in uncoupling, leading to death or serious injury.

Be sure the **LOAD RATING** of the hitch ball is equal or greater than the load rating of the coupler.

Be sure the **SIZE** of the hitch ball matches the size of the coupler.

- Wipe the hitch ball clean and inspect it visually and by feel for flat spots, cracks and pits.

### WARNING

A worn, cracked or corroded hitch ball can fail while towing, and may result in death or serious injury.

Before coupling trailer, inspect the hitch ball for wear, corrosion and cracks.

Replace worn or damaged hitch ball.

- Rock the ball to make sure it is tight to the hitch, and visually check that the hitch ball nut is solid against the lock washer and hitch frame.
- Wipe the inside and outside of the coupler clean and inspect it visually for cracks and deformations; feel the inside of the coupler for worn spots and pits.
- Be sure the coupler is tight to the tongue of the trailer. All coupler fasteners must be visibly solid against the trailer frame.

### WARNING

A loose hitch ball nut can result in uncoupling, leading to death or serious injury.

Make sure the hitch ball is tight to the hitch before coupling the trailer.

## Coupling To The Tow Vehicle

- Raise the bottom surface of the coupler to be above the top of the hitch ball.

### **4.3.1.2 Prepare The Coupler and Hitch**

- Lubricate the hitch ball and the inside of the coupler with a thin layer of automotive bearing grease.
- Remove the safety latch pin and open the coupler locking mechanism.
  - In the open position, the coupler is able to drop fully onto the hitch ball.
  - See the coupler instructions for details of placing the coupler in the “open” position.
- Slowly back up the tow vehicle so that the hitch ball is near or aligned under the coupler.

### **4.3.1.3 Couple The Trailer To The Tow Vehicle**

- Lower the trailer tongue until the coupler fully engages the hitch ball. If the coupler does not line up with the hitch ball, adjust the position of the tow vehicle.
- Engage the coupler locking mechanism. In the engaged position, the locking mechanism securely holds the coupler to the hitch ball.
- Insert the safety lock pin through the hole in the locking mechanism.
- Be sure the coupler is all the way on the hitch ball and the locking mechanism is engaged. A properly engaged locking mechanism will allow the coupler to raise the rear of the tow vehicle. Using the trailer jack, test to see that you can raise the rear of the tow vehicle by 1 inch, after the coupler is locked to the hitch.

## Notice

The tongue jack can be damaged by overloading. Do not use the tongue jack to raise the tow vehicle more than 1 inch.

**If the coupler cannot be secured to the hitch ball, do not tow the trailer.** Call PJ Trailers, Inc. at 800-452-9116 or your dealer for assistance.

## Coupling To The Tow Vehicle

- Lower the trailer so that its entire tongue weight is held by the hitch, and continue retracting the jack to its fully retracted position.
- Fully retract jack drop leg and insert pin.
- Go to Section 4.3.3 “Rig The Safety Chains – Bumper Pull Trailer” to continue connecting trailer to tow vehicle.

### 4.3.2 Trailer with Ring and Pintle Coupler

A ring connects to the pintle that is located on or under the rear bumper of tow vehicle. This system of coupling a trailer to a tow vehicle is sometimes referred to as “bumper pull.”

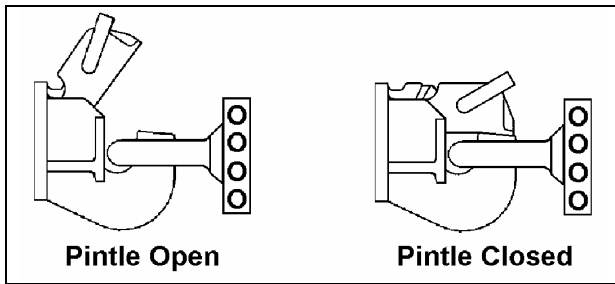

Trailer With Ring and Pintle Coupler - Figure 4-2

We have utilized a ring that is suitable for the size and weight of the trailer. The load rating of the ring and the necessary pintle size are listed on the trailer tongue. You must provide a pintle for your tow vehicle, where the load rating of the hitch and pintle is equal to or greater than that of your trailer. Also, the pintle size must be the same as the ring size. If the pintle is too small, too large, is underrated, is loose or is worn, the trailer can come loose from the tow vehicle, and may cause death or serious injury.

**THE TOW VEHICLE, HITCH AND PINTLE MUST HAVE A RATED TOWING CAPACITY EQUAL TO OR GREATER THAN THE TRAILER Gross Vehicle Weight Rating (GVWR).**

**IT IS ESSENTIAL THAT THE PINTLE BE OF THE SAME SIZE AS THE COUPLER.**

## Coupling To The Tow Vehicle

The pintle size and load rating (capacity) are marked on the pintle; ring capacity is marked on the ring.

### 4.3.2.1 **Before Coupling The Trailer To The Tow Vehicle**

Be sure the size and rating of pintle match the size and rating of the ring. Hitch ring and pintles are marked with their size and rating.

#### **WARNING**

Coupler-to-hitch mismatch can result in uncoupling, leading to death or serious injury.

Be sure the **LOAD RATING** of the pintle is equal or greater than the load rating of the ring.

Be sure the **SIZE** of the pintle matches the size of the ring.

- Wipe the pintle clean and inspect it visually and by feel for flat spots, cracks and pits.

#### **WARNING**

A worn, cracked or corroded pintle can fail while towing, and may result in death or serious injury.

Before coupling trailer, inspect the pintle for wear, corrosion and cracks.

Replace worn or damaged pintle.

- Rock the pintle to make sure it is tight to the hitch, and visually check that the pintle fasteners are solid against the hitch frame.
- Wipe the inside and outside of the ring clean and inspect it visually for cracks and deformations; feel the inside of the ring for worn spots and pits.
- Be sure the ring is tight to the tongue of the trailer. All ring fasteners must be visibly solid against the trailer frame.

## Coupling To The Tow Vehicle

### WARNING

A loose pintle can result in uncoupling, leading to death or serious injury. Make sure the pintle is tight to the hitch before coupling the trailer.

- Raise the bottom surface of the ring to be above the top of the open pintle.

#### **4.3.2.2 Prepare The Ring and Pintle**

- Lubricate the inside of the pintle with a thin layer of automotive bearing grease.
- Remove the safety latch pin and open the pintle locking mechanism.
  - In the open position, the ring is able to drop fully onto the pintle.
  - See the coupler instructions for details of placing the pintle in the “open” position.
- Slowly back up the tow vehicle so that the pintle is near or aligned under the ring.

#### **4.3.2.3 Couple The Trailer To The Tow Vehicle**

- Lower the trailer tongue until the ring fully engages the pintle. If the ring does not line up with the pintle, adjust the position of the tow vehicle.
- Engage the pintle locking mechanism. In the engaged position, the locking mechanism securely holds the ring to the pintle.
- Insert the safety lock pin through the hole in the locking mechanism.
- Be sure the ring is all the way on the pintle and the locking mechanism is engaged. A properly engaged locking mechanism will allow the pintle to raise the rear of the tow vehicle. Using the trailer jack, test to see that you can raise the rear of the tow vehicle by 1 inch, after the coupler is locked to the hitch.

### Notice

The tongue jack can be damaged by overloading. Do not use the tongue jack to raise the tow vehicle more than 1 inch.

## Coupling To The Tow Vehicle

**If the ring cannot be secured to the pintle, do not tow the trailer.**  
Call PJ Trailers, Inc. at 800-452-9116 or your dealer for assistance.

- Lower the trailer so that its entire tongue weight is held by the hitch, and continue retracting the jack to its fully retracted position.
- Fully retract jack drop leg and insert pin.
- Go to Section 4.3.3 “Rig The Safety Chains – Bumper Pull Trailer” to continue connecting trailer to tow vehicle.

### 4.3.3 Rig The Safety Chains – Bumper Pull Trailers

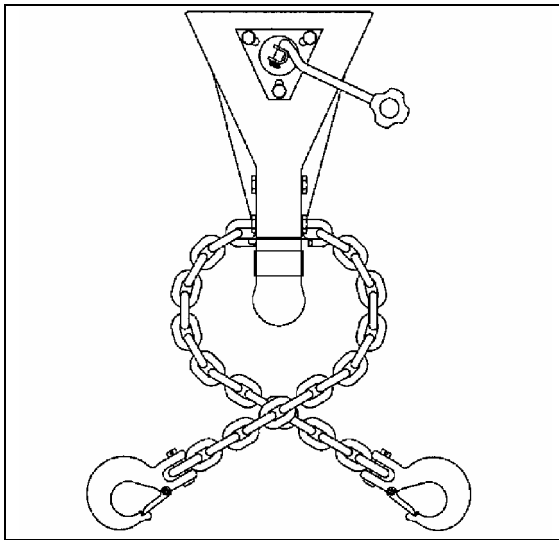

Proper Safety Chain Arrangement – Figure 4-3

- Visually inspect the safety chains and hooks for wear or damage. Replace worn or damaged safety chains and hooks before towing.
- Rig the safety chains so that they:
  - Cris-cross underneath the coupler so if the trailer uncouples, the safety chains can hold the tongue up above the road. See figure 4-3.
  - Loop around a frame member of the tow vehicle or to holes provided in the hitch system (but, do **not** attach them to an interchangeable part of the hitch assembly).

## Coupling To The Tow Vehicle

- Attach hooks up from underneath the hole (do not just drop into hole); and
- Provide enough slack to permit tight turns, but not be close to the road surface to drag.

### WARNING

Incorrect rigging of the safety chains can result in loss of control of the trailer and tow vehicle, leading to death or serious injury, if the trailer uncouples from the tow vehicle.

Chains must:

- Fasten to frame of tow vehicle, not to hitch or ball.
- Cross underneath hitch and coupler with minimum slack to permit turning and to hold tongue up, if the trailer comes loose.

### **4.3.4 Connect The Electrical Cable – Bumper Pull Trailers**

Connect the trailer lights to the tow vehicle's electrical system using the 7-pin connector.

- Check **all** lights for proper operation. Repair if needed.
- Check electric brakes for proper operation using brake controller mounted in the cab.

If your trailer has electric brakes, your tow vehicle will have an electric brake controller that sends power to the trailer brakes. Before towing the trailer on the road, you must operate the brake controller while trying to pull the trailer in order to confirm that the electric brakes operate. While towing the trailer at less than 5 m.p.h., manually operate the electric brake controller in the tow vehicle cab. You should feel the operation of the trailer brakes.

## Coupling To The Tow Vehicle

### WARNING

Improper electrical connection between the tow vehicle and the trailer will result in inoperable lights and electric brakes, and can lead to collision.

Before each tow:

- Check that all lights and turn signals work.
- Check that the electric brakes work by operating the brake controller inside the tow vehicle.

#### **4.3.5 Attach and Test Electric Breakaway Brake System – Bumper Pull Trailers**

If the coupler or hitch fails, a properly connected and working breakaway brake system will apply electric brakes on the trailer. The safety chains will keep the tow vehicle attached and as the brakes are applied at the trailer's axles, the trailer/tow vehicle combination will come to a controlled stop.

The breakaway brake system includes a battery, a switch with a pullpin and lanyard, and a breakaway brake controller. Read and follow the instructions here as well as the instructions that have been prepared by the breakaway brake manufacturer. If you do not have these instructions, call PJ Trailers, Inc. at 800-452-9116 for a free copy.

The breakaway brake system battery will trickle charge from the tow vehicle. Dump trailers and trailers with 12 volt hydraulic pumps will use the hydraulic pump battery for the breakaway brakes and will not be equipped with the battery charger shown in figure 4-4. If the electrical system on your tow vehicle does not provide power to the battery, you must periodically charge the battery with a commercial battery charger to keep the battery charged.

The "Charging" lamp (1) will be illuminated when the battery is receiving a charge from the tow vehicle. Press the "Test" button (2) to test the battery level of charge. Do not tow trailer if the battery requires recharging. A discharged breakaway brake battery will not activate the brakes if the trailer uncouples from the tow vehicle. The battery must be fully charged before towing trailer. See figure 4-4.

## Coupling To The Tow Vehicle

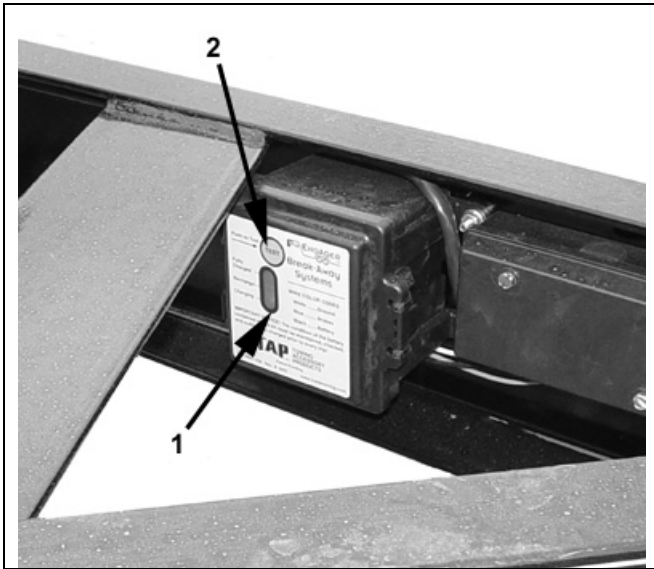

Breakaway Brake Battery Charger – Figure 4-4

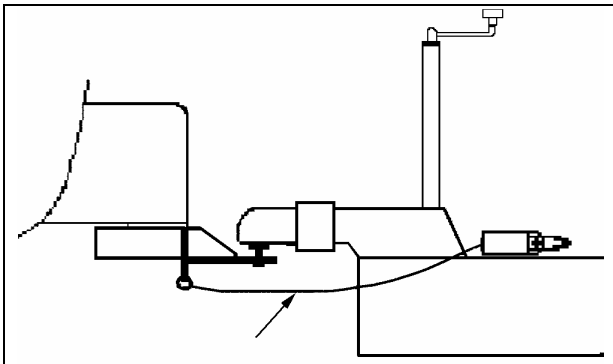

Breakaway Brake Lanyard – Figure 4-5

- Connect the pullpin lanyard to the tow vehicle so that the pullpin will be pulled out before all of the slack in the safety chains is taken up. See figure 4-5. Do **not** connect the pullpin cable to a safety chain, hitch ball or hitch ball assembly. This would keep the breakaway brake system from operating when it is needed.

## Coupling To The Tow Vehicle

- To test the breakaway brake battery, remove the pullpin from the switch and attempt to pull the trailer forward. You should feel the trailer resisting being towed, but the wheels will not necessarily be locked. If the brakes do not function, do not tow the trailer until brakes, or battery, are repaired.
- Immediately replace the pullpin. The breakaway brake system battery discharges rapidly when the pullpin is removed.

### WARNING

An ineffective breakaway brake system can result in a runaway trailer, leading to death or serious injury, if the coupler or ball hitch fails.

Connect the breakaway cable to the tow vehicle; and NOT to the hitch, ball or support.

Before towing the trailer, test the function of the breakaway brake system. If the breakaway brake system is not working, do not tow the trailer. Have it serviced or repaired.

Do **not** tow the trailer with the breakaway brake system ON because the brakes will overheat which can result in permanent brake failure.

### WARNING

Failure to replace the pullpin can result in ineffective brakes, leading to loss of control, serious injury or death.

If you do not use your trailer for three or more months, or during winter months:

- Store the battery indoors; and
- Charge the battery every three months.

Replace the breakaway brake battery according to the intervals specified by battery manufacturer.

## Coupling To The Tow Vehicle

### 4.3.6 Uncoupling Bumper Pull Trailer

Follow these steps to uncouple your ball hitch trailer from the tow vehicle:

- Block trailer tires to prevent the trailer from rolling, before jacking the trailer up.
- Disconnect the electrical connector.
- Disconnect the breakaway brake switch lanyard.
- Disconnect the safety chains from the tow vehicle.
- Unlock the coupler and open it.
- Before extending jack, make certain the ground surface below the jack pad will support the tongue load.
- Rotate the jack handle (or crank) clockwise. This will slowly extend the jack and transfer the weight of the trailer tongue to the jack.
- Raise the trailer to above the tow vehicle hitch.

### 4.4 GOOSENECK TRAILER WITH BALL COUPLER

A gooseneck ball coupler on the trailer connects to a gooseneck ball that you must have installed in the bed of the tow vehicle. Figure 4-6 shows a trailer with a gooseneck ball coupler. If your trailer is equipped with a fifth wheel or king pin, see the instruction provided by the manufacturer.



Gooseneck Trailer With Ball Coupler – Figure 4-6

## Coupling To The Tow Vehicle

We have utilized a gooseneck ball receiver that is suitable for the size and weight of the trailer. The load rating of the coupler and the necessary ball size are listed on the gooseneck.

You must provide a gooseneck ball and support structure that is marked with a rating that meets or exceeds the GVWR of your trailer **and** matches the size of the gooseneck ball receiver. If the gooseneck ball is too small, is underrated, is loose or is worn, the trailer can come loose from the tow vehicle, and may lead to death or serious injury.

**THE TOW VEHICLE, SUPPORT STRUCTURE AND GOOSENECK BALL MUST HAVE A RATED TOWING CAPACITY EQUAL TO OR GREATER THAN THE TRAILER Gross Vehicle Weight Rating (GVWR).**

**IT IS ESSENTIAL THAT THE GOOSENECK BALL BE OF THE SAME SIZE AS THE GOOSENECK BALL RECEIVER.**

The ball size and load rating (capacity) are marked on the ball; hitch capacity is marked on the hitch.

### **WARNING**

Coupler-to-hitch mismatch can result in uncoupling, leading to death or serious injury.

Be sure the **LOAD RATING** of the hitch ball is equal or greater than the load rating of the coupler.

Be sure the **SIZE** of the hitch ball matches the size of the coupler.

A gooseneck trailer will have one or two drop leg jacks for raising and lowering the gooseneck ball receiver. Because several drop leg jack mechanisms are available, the general instructions below may vary slightly from the jack manufacturer's instructions. If the trailer jack on your trailer does not resemble the jack shown in the figure 4-7, follow the instructions provided by the jack manufacturer. If you do not have these instructions, call PJ Trailers, Inc. at 800-452-9116 for a free copy.

## Coupling To The Tow Vehicle

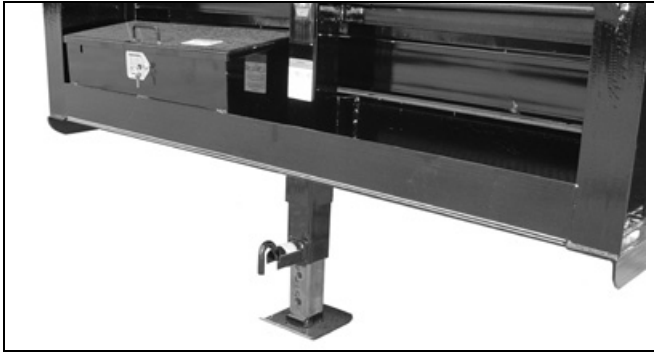

Drop Leg Jack – Figure 4-7

### 4.4.1 **Before Coupling The Trailer To The Tow Vehicle**

- Be sure the size and rating of the gooseneck ball match the size and rating of the receiver. Gooseneck balls and receivers are marked with their size and ratings.
- Wipe the gooseneck ball clean and inspect it visually and by feel for flat spots, cracks and pits.

### **WARNING**

A worn, cracked or corroded gooseneck ball can fail while towing, and may result in death or serious injury.

Before coupling the trailer, inspect the gooseneck ball for wear, corrosion and cracks; and replace worn or damaged gooseneck ball.

- Rock the ball to make sure it is tight to the ball support, and visually check that the gooseneck ball nut is solid against the lock washer and ball support frame.

## Coupling To The Tow Vehicle

### WARNING

A loose gooseneck ball can result in uncoupling, leading to death or serious injury.

Make sure the gooseneck ball nut is tight before coupling the trailer.

- Wipe the inside and outside of the receiver clean and inspect it visually for cracks; and feel the inside of the receiver for worn spots and pits. If any of these conditions exist, have the receiver replaced before coupling the trailer.
- Lubricate the inside of the gooseneck ball receiver with automotive bearing grease.
- Be sure the receiver is tight to the trailer. All receiver fasteners must be visibly solid against the trailer frame.
- Release the jack handle or crank from its holder.
- Rotate the handle/crank clockwise to raise the bottom surface of the gooseneck to be above the top of the gooseneck ball.

#### **4.4.2 Prepare The Ball And Ball Receiver**

- Release the lock plate on the gooseneck ball receiver. With the spring-loaded lock plate locking pin in the OPEN position, rotate the lock plate to a position that allows the gooseneck ball to enter the receiver.
- Slowly back up the tow vehicle so that the gooseneck ball is aligned under the gooseneck ball receiver.

### WARNING

If the trailer drops during coupling, death or serious injury may result.

There must be no one under the trailer or coupler before or during the coupling operation.

#### **4.4.3 Couple The Trailer To The Tow Vehicle**

- Rotate the jack handle counter-clockwise. This will retract the jack causing the gooseneck ball receiver to drop down so it can fully

## Coupling To The Tow Vehicle

engage the gooseneck ball and transfer the weight of the trailer tongue to the towing vehicle hitch. If the receiver does not line up with the ball, raise the receiver again and adjust the position of the tow vehicle. Then lower the receiver over the ball. When the drop leg base is no longer resting on the ground, the towing vehicle hitch is holding all of the weight of the trailer tongue.

- Close the lock plate on the gooseneck ball receiver.
- Move the spring-loaded lock plate locking pin to the CLOSED position. Be sure the locking pin is holding the lock plate.
- Be sure the receiver is all the way on the gooseneck ball and the lock plate is engaged. A properly engaged locking mechanism will allow the coupler to raise the rear of the tow vehicle. Using the trailer jack, test to see that you can raise the rear of the tow vehicle by 1 inch.

### Notice

The drop leg jack can be damaged by overloading. Do not use the drop leg jack to raise the tow vehicle more than 1 inch.

**If the gooseneck receiver cannot be secured to the ball, do not tow the trailer.** Call PJ Trailers, Inc. at 800-452-9116 or your dealer for assistance.

- After testing to see that the receiver is properly secured and locked to the ball, retract the jack to its fully retracted position.
- Return the drop leg(s) to their upper positions. The drop leg(s) are held in the lowered position with a plunger pin. Rotating the plunger pin while pulling it outward will cause it to come out of engagement with the drop leg and the leg will rapidly rise.

### Caution

The drop legs are heavily spring loaded in the lowered position. They will rapidly return to the upper position when released and can inflict serious bruises, scrapes or pinching.

Keep your feet, shins and hands well clear of the drop legs and drop leg bases when releasing the drop legs.

## Coupling To The Tow Vehicle

### 4.4.4 Rig The Safety Chains

- Visually inspect the safety chains and hooks for wear or damage. Replace worn or damaged safety chains and hooks before towing.
- Rig the safety chains so that they attach to the “safety chain receivers” in the bed of the truck. If you are not certain of the hitch provisions for receiving safety chains, contact the hitch manufacturer or installer. Do NOT attach the safety chains to the gooseneck ball or its support; and
- Rig the safety chains so they have sufficient slack to permit turning, but not too much slack – the safety chains must keep the gooseneck on the tow vehicle bed if the trailer uncouples. See figure 4-8.

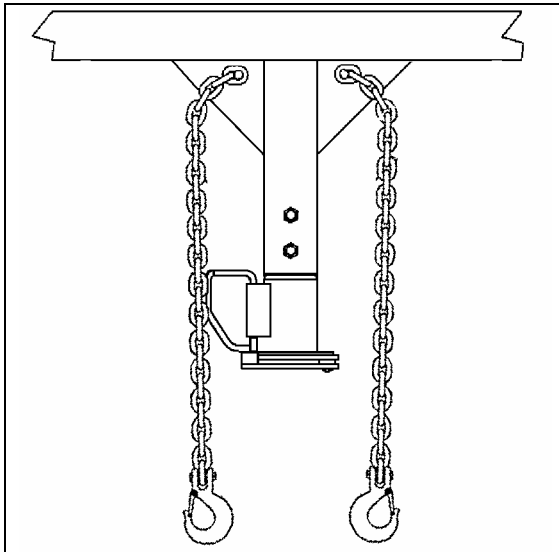

Safety Chain Arrangement - Figure 4-8

## Coupling To The Tow Vehicle

### **WARNING**

Improper rigging of the safety chains can result in loss of control of the trailer and tow vehicle, leading to death or serious injury, if the trailer uncouples from the tow vehicle.

- Fasten chains to safety chain receivers on the hitch, not to ball.
- Have sufficient slack to permit turning and to keep gooseneck on bed of the tow vehicle, if the trailer comes loose.

#### **4.4.5 Connect The Electrical Cable**

Connect the trailer lights to the tow vehicle's electrical system using the electrical connector.

- Check all lights for proper operation:
  - Clearance and Running Lights (Turn on tow vehicle headlights).
  - Brake Lights (Step on tow vehicle brake pedal).
  - Turn Signals (Operate tow vehicle directional signal lever).
- Check electric brakes for proper operation

If your trailer has electric brakes, your tow vehicle will have an electric brake controller that sends power to the trailer brakes. Before towing the trailer on the road, you must operate the brake controller while trying to pull the trailer in order to confirm that the electric brakes operate. While towing the trailer at less than 5 m.p.h., manually operate the electric brake controller in the tow vehicle cab. You should feel the operation of the trailer brakes.

## Coupling To The Tow Vehicle

### **WARNING**

Improper electrical connection between the tow vehicle and the trailer will result in inoperable lights and electric brakes, and can lead to collision.

Before each tow:

- Check that all lights and turn signals work
- Check that the electric brakes work by operating the brake controller inside the tow vehicle

#### **4.4.6 Attach and Test The Breakaway Brake System**

If the coupler or hitch fails, a properly connected and working breakaway brake system will apply electric brakes on the trailer. The safety chains will keep the tow vehicle attached and as the brakes are applied at the trailer's axles, the trailer/tow vehicle combination will come to a controlled stop.

The trailer breakaway brake system includes a battery, a switch with a pullpin and lanyard, and a breakaway brake controller. Read and follow the instructions here as well as the instructions that have been prepared by the breakaway brake controller manufacturer. If you do not have these instructions, call PJ Trailers, Inc. at 800-452-9116 for a free copy.

The breakaway brake system battery will trickle charge from the tow vehicle. Dump trailers and trailers with 12 volt hydraulic pumps will use the hydraulic pump battery for the breakaway brakes and will not be equipped with the battery charger shown in figure 4-9. If the electrical system on your tow vehicle does not provide power to the battery, you must periodically charge the battery with a commercial battery charger to keep the battery charged.

The "Charging" lamp (1) will be illuminated when the battery is receiving a charge from the tow vehicle. Press the "Test" button (2) to test the battery level of charge. Do not tow trailer if the battery requires recharging. A discharged breakaway brake battery will not activate the brakes if the trailer uncouples from the tow vehicle. The battery must be fully charged before towing trailer. See figure 4-9.

## Coupling To The Tow Vehicle

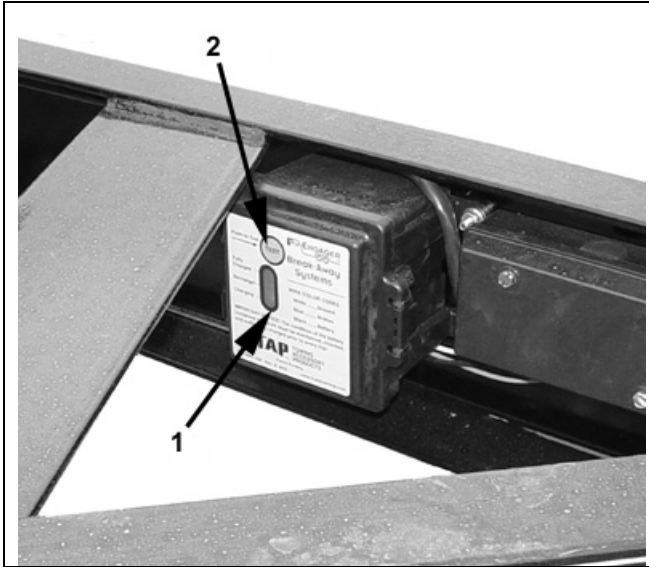

Breakaway Brake Battery Charger – Figure 4-9

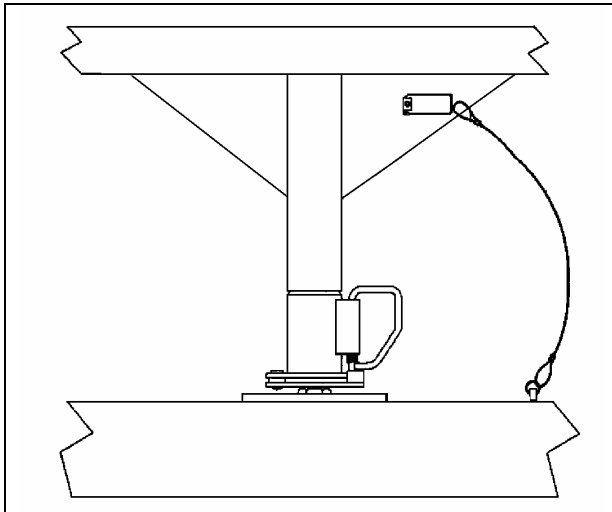

Breakaway Brake Lanyard – Figure 4-10.

- Visually inspect the breakaway brake system for broken parts.
- Connect the pullpin lanyard to the tow vehicle so that the pullpin will be pulled out before all of the slack in the safety chains is taken up.

## Coupling To The Tow Vehicle

See figure 4-10. Do **not** connect the pullpin lanyard to a safety chain, safety chain receiver or to the gooseneck ball or its support. This would keep the breakaway brake system from operating when it is needed. Contact the hitch manufacturer or installer if you are not certain of the hitch provisions for breakaway brake connection.

- To check the breakaway brake battery pull out the pullpin from the switch and attempt to pull the trailer forward. You should feel the trailer resisting being towed, but the wheels will not necessarily lock up.
- Immediately replace the pullpin. The breakaway brake system battery discharges rapidly when the pullpin is removed.

### WARNING

An ineffective or inoperative breakaway brake system can result in a runaway trailer leading to death or serious injury if the coupler or hitch fails.

Connect the breakaway lanyard to the tow vehicle; and **NOT** to the safety chain, safety chain receiver, gooseneck ball or gooseneck ball support.

Test the function of the breakaway brake system before towing the trailer. Do not tow the trailer if the breakaway brake system is not working. Have it serviced or repaired.

Do **not** tow the trailer with the breakaway brake system **ON** because the brakes will overheat which can result in permanent brake failure.

### WARNING

Failure to replace the pullpin can result in ineffective brakes, leading to loss of control, serious injury or death.

If you do not use your trailer for three or more months, or during winter months:

- Store the battery indoors; and
- Charge the battery every three months.

## Coupling To The Tow Vehicle

Replace the breakaway brake battery at intervals recommended by the battery manufacturer's instructions.

### **4.4.7 Uncoupling Gooseneck Trailer With Ball Coupler**

Follow these steps to uncouple your gooseneck hitch trailer from the tow vehicle:

- Park the trailer on a firm level surface.
- Block trailer tires to prevent the trailer from rolling, before jacking the trailer up.
- Lower the tow vehicle tailgate.
- Disconnect the electrical connector.
- Disconnect the breakaway brake switch lanyard.
- Disconnect the safety chains from the tow vehicle.
- Move the spring-loaded gooseneck receiver lock plate locking pin to the OPEN position.
- Rotate the lock plate to a position that permits the gooseneck ball to exit the receiver.
- Before releasing dropleg jack, make certain ground surface below jack base will support the trailer tongue load.
- Rotate the drop leg plunger pin handle so that the plunger pin is released from the drop leg.
- Push down on the drop leg base with your foot to place a drop leg to the desired lowered position.
- Rotate the plunger pin handle so that the plunger pin is attempting to engage the drop leg.
- Slowly raise your foot, permitting the drop leg to raise. The plunger pin will engage a hole in the drop leg.

### **Caution**

The drop legs are heavily spring loaded in the lowered position. They will rapidly return to the upper position when released and can inflict serious bruises, scrapes or pinching.

Keep your feet, shins and hands well clear of the drop legs and drop leg bases when releasing the drop legs.

Always wear shoes or boots while performing this operation

## Coupling To The Tow Vehicle

- Be sure the plunger pin is fully engaged. Push it in by hand if necessary. The bent part of the plunger pin handle must be touching the plunger pin housing.
- If your trailer has two drop leg jacks, lower them both to the same level, following the above instructions.

### Notice

If the drop legs are not set at the same level, one of the drop leg jacks can be overloaded and can be damaged.

- Release the handle (or crank) from its holder and engage it with the jack shaft.
- Rotate the handle (or crank) clockwise to slowly extend the jack and transfer the weight of the trailer tongue to the jack.
- On two speed jacks, move the handle to engage high speed mode.
- When the drop leg base contacts the ground, shift the gearbox into low speed mode.

### Notice

Do not use high speed to lift the trailer, the drop leg jack mechanism can be damaged.

High speed is used only to rapidly move the drop leg base into contact with the ground.

- Continue to extend the jack(s), making sure that the ground is providing stable and level support for the trailer.
- After the jack(s) are extended and the gooseneck ball receiver is well clear of the gooseneck ball, to permit driving the tow vehicle away, disengage the handle from its shaft and return to its holder.

#### **4.5 TONGUE WEIGHT**

It is critical to have a portion of the trailer load carried by the tow vehicle. That is, the trailer tongue must exert a downward force on the hitch. This is necessary for two reasons. First, the proper amount of

## Coupling To The Tow Vehicle

tongue weight is necessary for the tow vehicle to be able to maintain control of the tow vehicle/trailer system. If, for example, the tongue exerts an upward pull on the hitch, instead of pushing down on it (because the trailer is overloaded behind its axle(s)), the rear wheel of the tow vehicle can lose traction or grip and cause loss of control. Also, even if there is some weight on the tongue, but not enough weight on the tongue, the trailer can become unstable at high speeds. Remember, the faster you go the more likely the trailer is to sway.

If, on the other hand, there is too much tongue weight, the tow vehicle is prone to jack-knife. Furthermore, the front wheels of the tow vehicle can be too lightly loaded and cause loss of steering control and traction, if the front wheels are driving.

In addition to tow vehicle control, tongue weight is necessary to insure that the trailer axle(s) do not exceed their Gross Axle Weight Rating (GAWR).

In the following table, the second column notes the rule of thumb percentage of total weight of the trailer plus its cargo (Gross Vehicle Weight, or "GVW") that should appear on the tongue of the trailer. For example, a trailer with a gooseneck hitch, with a loaded weight of 12,000 pounds, should have 20-25% of 12,000 pounds on the tongue. That is, the example trailer would have 2,400 to 3,000 pounds on its tongue.

Tongue Weight as a Percentage of Loaded Trailer Weight	
Type of Hitch	Percentage
Ball Hitch (or Bumper Hitch)	10-15% for large trailers 6-10% for smaller utility trailers
Gooseneck Hitch	20-25%
Fifth Wheel Hitch	

## Coupling To The Tow Vehicle

### WARNING

Improper tongue weight (load distribution) can result in loss of control of the trailer, leading to death or serious injury.

Make certain that tongue weight is within the allowable range.

Be sure to:

- Distribute the load front-to-rear to provide proper tongue weight (see chart);
- Distribute the load evenly, right and left, to avoid tire overload; and
- Keep the center of gravity low.

### **4.6 CHECKING TONGUE WEIGHT**

To check the tongue weight, the tow vehicle and trailer must be on level ground, as they will be when the trailer is being towed.

For lighter trailers the recommended method of checking tongue weight is to use an accessory called a “tongue weight scale.” If a tongue weight scale is not available from your dealer, call PJ Trailers at 800-452-9116 for assistance.

For most trailers, it is easier to go to a truck stop where there is a “certified” scale. Place the tow vehicle only onto the scale and get the weight. This weight must be less than your tow vehicle’s GVWR. Pull the trailer onto the scale and decouple it from the tow vehicle, leaving just the trailer on the scale. Get a ticket which lists the total trailer weight. Re-connect the trailer to your tow vehicle and drive the tow vehicle wheels off the scale, just leaving the trailer axles on the scale. Get a second “ticket”, which lists the trailer’s axle weight. Simply subtract the axle weight from the total weight to determine the hitch weight.

While you are at the scale, you should weigh the entire combination vehicle. This result should be less than the Gross Combined Weight Rating (GCWR) for your towing vehicle. Some scales allow you to get individual axle weights also. If this is possible, get the tow vehicles front and rear axle weights to make sure they are in the same proportion as the

## Coupling To The Tow Vehicle

tow vehicle alone, and that the rear axle is not overloaded. This is the best way to check that a weight distribution (or load leveling) hitch is adjusted properly, i.e., you have the proper number of chain links attached to the snap-up brackets.

### **4.7 ADJUST BUMPER PULL TRAILER HITCH HEIGHT**

The height of the hitch on the trailer must be adjusted so that the trailer, when loaded to rated capacity, is level while connected to the tow vehicle. A level trailer allows equal weight distribution on the axles.

Your dealer or a trailer service center can perform this adjustment or you can use the following steps to adjust the hitch height yourself.

#### **WARNING**

Improper hitch height adjustment can result in overloaded tires, blowout and loss of control, leading to death or serious injury.

Adjust the hitch height so that the loaded trailer is level.

- Connect trailer to tow vehicle and load the trailer to rated capacity (see Loading and Unloading The Trailer).
- Park the tow vehicle and trailer on a firm level surface.
- Stand away from the trailer and visually verify if the trailer is level front-to-rear. If the front of the trailer is higher than the rear, the hitch must be raised. If the front of the trailer is lower than the rear, the hitch must be lowered.
- Uncouple trailer from tow vehicle (See Uncoupling a Bumper Pull Trailer).
- Remove the lock nuts and cap screws (1) on hitch. **Discard** lock nuts. See figure 4-11.

## Coupling To The Tow Vehicle

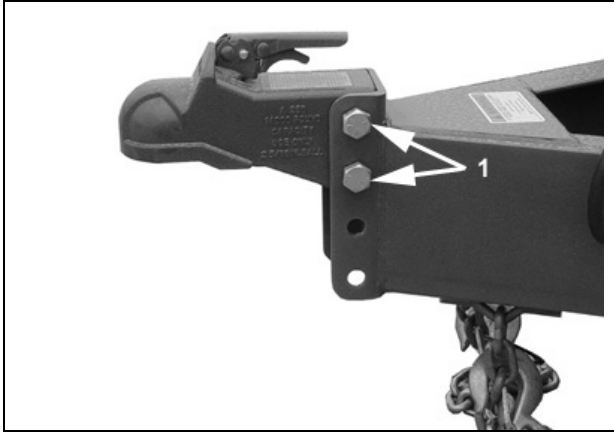

Adjust Hitch Height – Figure 4-11

### **WARNING**

Used lock nuts are prone to loosen, resulting in the hitch separating from the trailer, which can lead to death or serious injury.

NEVER re-use a lock nut.

Two new lock nuts are provided with your trailer to use for the hitch adjustment. Use new lock nuts each time the hitch height is adjusted.

Contact your dealer for the proper grade and size of lock nut.

- Raise or lower the hitch as necessary.
- Install cap screws (1) and **NEW** lock nuts. See figure 4-11.
- Tighten lock nuts to XX lb. ft. of torque.
- Couple the trailer to the tow vehicle, verify that the trailer is level front to rear. Adjust if necessary.
- Unload trailer (see Loading and Unloading The Trailer) and disconnect from tow vehicle (see Uncoupling a Bumper Pull Trailer).

### **4.8 ADJUST GOOSENECK COUPLER HEIGHT**

The height of the ball receiver on the trailer must be adjusted so that the trailer, when loaded to rated capacity, is level while connected to the tow vehicle. A level trailer allows equal weight distribution on the axles.

## Coupling To The Tow Vehicle

There must also be adequate clearance between the bottom of the trailer and the sides of the tow vehicle bed.

Connect trailer to tow vehicle (see Coupling To The Tow Vehicle) and load the trailer to rated capacity (see Loading and Unloading The Trailer). Park the tow vehicle and trailer on a firm level surface.

Stand back from the trailer and visually verify if the trailer is level front-to-rear. If the front of the trailer is higher than the rear, the hitch must be retracted. If the front of the trailer is lower than the rear, the hitch must be extended.

Uncouple trailer from tow vehicle (See Coupling To The Tow Vehicle).

Loosen the jam nut(s) and setscrew(s) (1). Remove safety lock pin (2) and load bearing pin (3). Extend or retracted the receiver as needed. The maximum the receiver can be extended is 8 inches. See figure 4-14.

Insert load bearing pin (3) through hole in receiver and install safety lock pin (2) Tighten setscrew(s) (1) and jam nut(s) to the proper torque values listed below. **Never** use the setscrew or any other device as a replacement for the load bearing pin (3).

<u>Coupler Rating</u>	<u>Setscrew Torque</u>	<u>Jam Nut Torque</u>
20,000 lb Round	160 lb. ft.	85 lb. ft.
25,000 lb Round	88 lb. ft.	85 lb. ft.
25,000 lb Square	160 lb. ft.	85 lb. ft.
30,000 lb Round	88 lb. ft.	85 lb. ft.

### WARNING

Improper gooseneck height adjustment can result in overloaded tires, blowout and loss of control, leading to death or serious injury.

Adjust the gooseneck receiver so that the loaded trailer runs level.

# Coupling To The Tow Vehicle

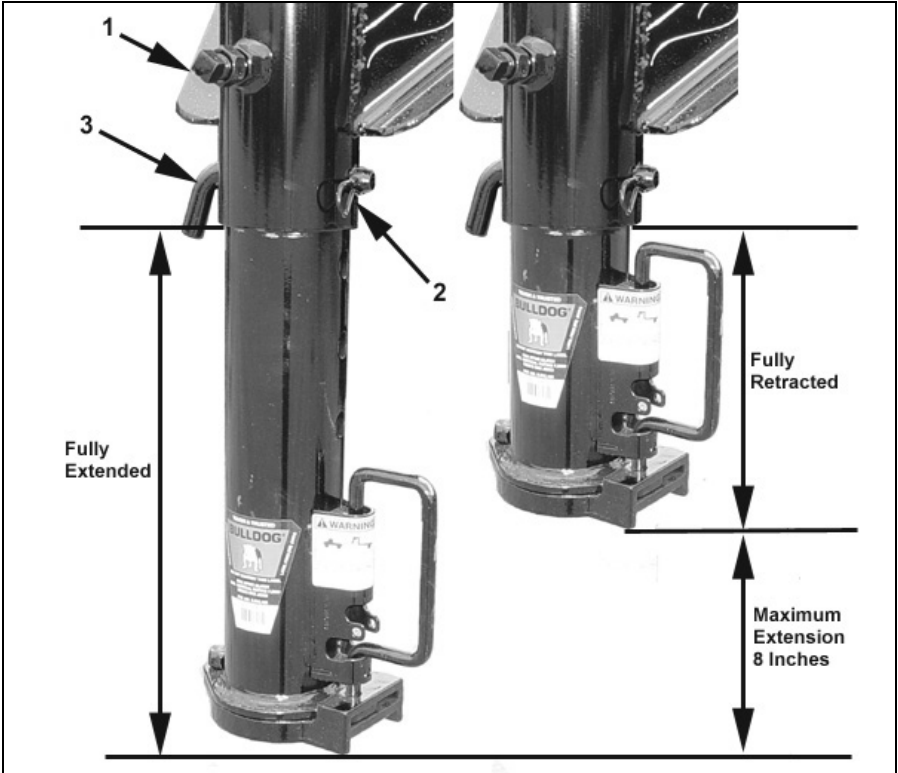

Gooseneck Height Adjustment – Figure 4-14

## 5 LOADING AND UNLOADING A DUMP TRAILER

Improper trailer loading causes many accidents and deaths. To safely load a trailer, you must consider:

- Overall load weight;
- Load weight distribution;
- Proper tongue weight; and
- Securing the load properly.

To determine that you have loaded the trailer within its rating, you must consider the *distribution* of weight, as well as the total weight of the trailer and its contents. The trailer axles carry most of the total weight of the trailer and its contents (Gross Vehicle Weight, or “GVW”). The remainder of the total weight is carried by the tow vehicle hitch. It is essential for safe towing that the trailer tongue and tow vehicle hitch carry the proper amount of the loaded trailer weight, otherwise the trailer can develop an undesirable sway at towing speeds, or the rear of the towing vehicle can be overloaded. Read the “Tongue Weight” information in Section 4.

The load distribution must be such that no component part of the trailer is loaded beyond its rating. This means that you must consider the rating of the tires, wheels and axles. For tandem and triple axle trailers, you must make sure that the front-to-rear load distribution does not result in overloading any axle.

Towing stability also depends on keeping the center of gravity as low as possible. Load heavy items on the floor and over the axles. When loading additional items, be sure to maintain even side-to-side weight distribution and proper tongue weight. The total weight of the trailer and its contents must never exceed the total weight rating of the trailer (Gross Vehicle Weight Rating, or “GVWR”).

# Loading And Unloading A Dump Trailer

## Hazards For Dump Trailers

A dump trailer is specifically designed for hauling equipment or cargo that is to be dumped, not for transporting livestock. The major hazards associated with dump trailers are:

- Overloading.
- Improper weight distribution; both side to side and front to back.
- Getting under a raised dump body.
- Not using, or improperly using the body prop.
- Modifying or altering hydraulic components.
- Modifying or altering dump controls.
- Not dumping from a solid and level foundation.
- Not fully opening rear doors when dumping.
- Jerking the trailer, or hydraulics, to loosen the load.
- Trailer coming near or contacting overhead power lines when body is raised.

### WARNING

An overloaded trailer can result in loss of control of the trailer, leading to death or serious injury.

Do not exceed the trailer Gross Vehicle Weight Rating (GVWR) or an axle Gross Axle Weight Rating (GAWR).

Do not load a trailer so that the weight on any tire exceeds its rating.

### WARNING

A soft and/or uneven surface may cause the tow vehicle and trailer to tip over when the dump body is raised.

Raise the dump body ONLY if the tow vehicle and trailer are both on a firm and level surface.

# Loading And Unloading A Dump Trailer

## WARNING

An overloaded trailer or improperly distributed load can result in death or serious injury.

An overloaded trailer can cause the hydraulic system to malfunction, resulting in the dump body falling.

A load that is improperly distributed in the trailer can result in the trailer tipping over when the dump body is raised.

## Danger

**NEVER** alter or substitute any hydraulic system component. Death or serious injury may result.

An altered or component substituted hydraulic system may malfunction, resulting in the dump body falling without warning.

**NEVER** alter or substitute any hydraulic system component.

## WARNING

Risk of electrocution.

Dump body coming near or contacting power lines can cause electrocution. Electrocution can occur without contact.

Be sure there are no overhead power lines over or near the trailer before raising dump body.

## 5.1 LOADING FIXED LOADS

(Including equipment such as skid-steer loaders, mowers, etc.)

- Fixed loads that are to be carried or dumped should be loaded evenly throughout the trailer. Too much load in the front portion will strain and possibly overload the hydraulic hoist. Too much load in the rear can lead to trailer swaying at highway speeds.
- Couple the trailer to the tow vehicle.

## Loading And Unloading A Dump Trailer

- Park the tow vehicle and trailer on a firm and level surface, both front-to-back and side-to-side. Attempting to load on a soft or uneven surface may cause the trailer to overturn, which can result in death or serious injury.
- Inspect the “D” rings for any cracks.
- Clear the area around the trailer.

### WARNING

Load can suddenly move or topple, which can result in death or serious injury.

Do not load or unload trailer unless coupled to tow vehicle and is on a firm and level surface.

- Place blocking under the rear of the trailer so the weight of the cargo does not raise the front of the trailer during loading.
- Open rear swing gates and secure open.

### Caution

The weight of each loading ramp is 80 lbs.

Use a safe lifting procedure to prevent injury when handling ramps.

- Remove safety lock pins (1), open covers and pull ramps from storage position. See figure 5-1.



Ramp Safety Lock Pins - Figure 5-1

## Loading And Unloading A Dump Trailer

- Place bracket (2) on ramps over bracket (3) trailer. See figure 5-2.

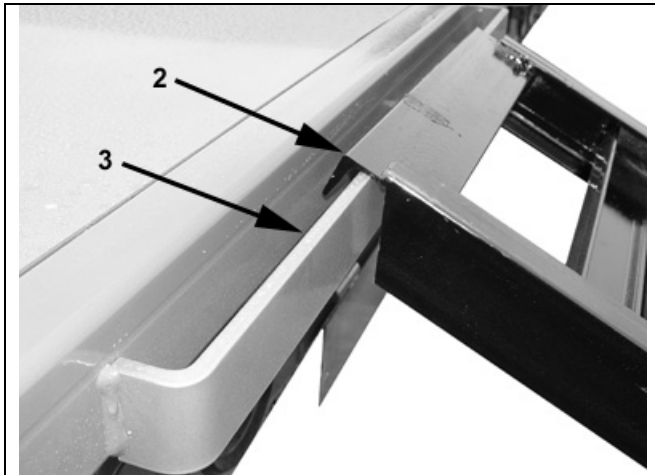

Install Ramps – Figure 5-2

- Place the ramps at the proper width and load the equipment. The operator must be experienced and skilled to perform the loading and unloading.
- Secure the cargo to the trailer using appropriate straps, chains and tensioning devices. Refer to [www.fmsca.dot.gov](http://www.fmsca.dot.gov) for regulations regarding cargo securement rules.
- Remove ramps and place in storage position. Close ramp covers and be certain to install safety lock pins (1) on ramp covers. See figure 5-1.
- Close and secure rear doors.
- Remove blocking under rear of trailer

### **5.2 LOADING AND UNLOADING BULK MATERIALS**

**Payload Capacity:** Check if the trailer has “payload” decals on the sides. If not, then determine the payload, or Cargo Capacity, by subtracting the empty weight of the trailer from the GVWR given on the Certification / VIN tag. Determine the density of the material to be loaded and dumped so that you will know, approximately, how many cubic yards of material may be safely loaded, carried, and dumped.

## Loading And Unloading A Dump Trailer

### WARNING

Trailer, hitch or dump body can fail.

You or others can die or be seriously injured.

Load in the trailer must not exceed capacity and must be distributed evenly.

### **5.2.1 Prepare Trailer For Loading**

Couple the trailer to the towing vehicle before loading. This is essential because the tongue can raise during loading. To measure the tongue weight you will have to de-couple the trailer after it is loaded.

Be sure the trailer is located on firm level ground. Attempting to load on uneven ground may cause the trailer to overturn, which can result in serious injury or death.

Do not transport people, containers of hazardous substances, or flammable liquids. The exception is fuel in the tank of vehicles or equipment that are being hauled.

### WARNING

Do not transport flammable, explosive, poisonous or other dangerous materials in your trailer. The exception is fuel in the tank of vehicles or equipment that are being hauled.

## Loading And Unloading A Dump Trailer

### **WARNING**

**RAISED DUMP BODY CAN DROP OR TIP OVER SUDDENLY. YOU AND OTHERS CAN DIE OR BE SERIOUSLY INJURED.**

**YOU MUST:**

- Have trailer on level, firm ground before dumping.
- Keep others away while dumping.
- Stay at controls until dump body is down.

**NEVER LEAVE THE SCENE WHEN DUMP BODY IS LIFTED.**

- Lock hoist controls after use.
- Have dump body down before moving trailer.
- Use body-prop and have dump body empty before getting under raised dump body.
- If the hoist does not lift the load:
  - Manually reduce the load - obtain service from a qualified hydraulics technician.

**NEVER ASSIST THE HOIST. (i.e., with a jack, crane, heavy equipment, etc.**

- If the load does not leave the dump body: Lower the dump body and manually free the load.
- Never attempt to free a load from a raised dump body.

### **5.2.2 Loading Bulk Material**

- Couple the trailer to the tow vehicle.
- Park the trailer and tow vehicle on a firm and level surface, both side-to-side and front-to-rear.
- Check the dump body for damage. Repair before loading trailer.
- Close and latch trailer gates.
- Tell the loader operator the GVWR of your trailer. The loader operator will have an approximate weight of the material to be loaded.
- Use common sense when loading. If you are uncertain of the weight of the material, load a small amount and weigh your trailer. It is

## Loading And Unloading A Dump Trailer

much easier to add to a light load than to remove material from an overloaded trailer.

- Level (evenly distribute) the load within the trailer from front to back and from side to side.
- If material may blow out while driving, tarp the trailer.
- If the trailer is overloaded, **DO NOT attempt to raise the dump body**. The excess material must be removed by equipment designed for this purpose, or by hand.

### 5.2.3 Unload Bulk Material Using The Spreader Gate

- Read and understand the hoist operating procedure before operating the dump body.
- Clear the area around the dump trailer.
- Park the tow vehicle and trailer on a firm and level surface both left / right and front / rear. Attempting to unload on a soft or uneven surface may cause the trailer to overturn, which can result in death or serious injury.
- For spreading material, the surface in which the tow vehicle and trailer will travel **MUST** be firm and level.

#### **WARNING**

A soft and/or uneven surface may cause the tow vehicle and trailer to overturn when the dump body is raised or while spreading material.

Raise the dump body **ONLY** if the tow vehicle and trailer are both on a firm and level surface.

#### **WARNING**

An overloaded trailer or improperly distributed load can result in death or serious injury.

An overloaded trailer can cause the hydraulic system to malfunction, resulting in the dump body falling.

A load that is improperly distributed in the trailer can result in the trailer overturning when the dump body is raised.

## Loading And Unloading A Dump Trailer

- Set the metering chains (1) at the desired number of links to control the opening distance of the spreader gate. Be sure to set both chains at equal length. Push down on lever (2) to unlock spreader gate. See figure 5-3.

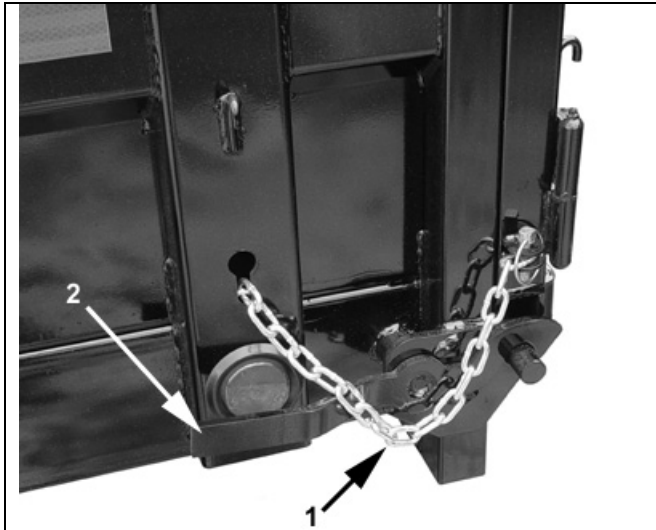

Set Metering Chains and Unlock Spreader Gate – Figure 5-3

### **⚠ Caution**

Loaded materials can exert pressure against the spreader gate. This may cause the spreader gate to swing out with force when unlocked, causing serious injury.

Stand on the side of the trailer to unlock spreader gate.

- Open the battery box and locate the dump body controller. While using the dump body controller, position yourself in a safe location clear of the dump body. Check for overhead power lines and other obstructions before raising dump body.

## Loading And Unloading A Dump Trailer

### WARNING

Risk of electrocution.

Dump body coming near or contacting power lines may result in electrocution. Electrocution can occur without contact.

Be sure there are no overhead power lines over or near the trailer before raising dump body.

### Danger

A lowering or falling dump body can result in death or serious injury.

**NEVER** enter the area under the dump body unless the empty dump body is supported by the body prop.

### Danger

The body prop is designed to support an empty dump body only.

**NEVER** support a loaded dump body by the body prop.

Unload the dump body before using body prop.

- Press and hold button (3) to raise the dump body. Release the button when the body has reached approximately the halfway point of its dumping angle, or if the load begins to shift rearward. Never leave the dump body control when operating the dump body. See figure 5-4.

## Loading And Unloading A Dump Trailer



Remote or Pendant Dump Controller – Figure 5-4

### WARNING

Fully raising the loaded dump body may result in the tow vehicle rear wheels losing traction.

Do not fully raise a loaded dump body or place the entire load at the rear of trailer.

- Return the dump body control to the battery box. Watch for and avoid obstructions such as tree limbs, overhead lines, potholes, etc. and SLOWLY drive the tow vehicle and trailer ahead to spread the material.
- **DO NOT** drive forward and stop quickly to “shock” the load out of the body. **DO NOT** “jerk” the control button up and down to dislodge the load. **The proper procedure for a stuck load is to fully lower the dump and dislodge the material by hand.**
- You may need to raise the dump body higher after a portion of the load has been spread to place the remaining material at the rear of the dump body.

## Loading And Unloading A Dump Trailer

- Stop tow vehicle after all material has exited the dump body.
- Press and hold button (4) to lower the dump body. See figure 5-4. Release the button when the dump body is fully lowered. Place dump body controller in the storage or travel location. Close and lock battery box.
- Close and lock rear gate before moving trailer.

### 5.2.4 Unload Bulk Material Using The Swing Gates

- Read and understand the hoist operating procedure before dumping the load.
- Be sure the trailer is on level ground, both side-to-side and front-to-rear. Attempting to unload on uneven ground may cause the trailer to overturn, which can result in death or serious injury.

#### WARNING

A soft and/or uneven surface may cause the tow vehicle and trailer to overturn when the dump body is raised or while spreading material.

Raise the dump body ONLY if the tow vehicle and trailer are both on a firm and level surface.

#### WARNING

An overloaded trailer or improperly distributed load can result in death or serious injury.

An overloaded trailer can cause the hydraulic system to malfunction, resulting in the dump body falling.

A load that is improperly distributed in the trailer can result in the trailer overturning when the dump body is raised.

#### Caution

Loaded materials can exert pressure against the swing gates. This may cause the gates to swing out with force when unlatched, causing serious injury.

Stand away from the trailer to unlock swing gates.

## Loading And Unloading A Dump Trailer

- Clear the area around the dump trailer.
- Remove safety lock pin, pull up on gate latch (1) to release swing gates. See figure 5-5. Lock gates against the side of trailer.



Latch On Double Swing Gates – Figure 5-5

- Open the battery box and locate the dump body controller. While using the dump body controller, position yourself in a safe location clear of the dump body. Check for overhead power lines and other obstructions before raising dump body.

### **WARNING**

Risk of electrocution.

Dump body coming near or contacting power lines may result in electrocution. Electrocution can occur without contact.

Be sure there are no overhead power lines over or near the trailer before raising dump body.

## Loading And Unloading A Dump Trailer

### Danger

A lowering or falling dump body can result in death or serious injury.

**NEVER** enter the area under the dump body unless the empty dump body is supported by the body props.

### Danger

The body props are designed to support an empty dump body only.

**NEVER** support a loaded dump body by the body props.

Unload the dump body before using body props.

- Standing well clear of the dump body in a safe location, push and hold the up button (2) on the control until the dump body reaches approximately the **halfway point** of its dumping angle. See figure 5-6. Never leave the control when operating the dump body.



Remote or Pendant Dump Controller – Figure 5-6

## Loading And Unloading A Dump Trailer

- Discontinue pushing the up button and walk to the rear of the trailer so you can estimate if there is enough space for the remainder of the load to be safely dumped. If not, then you need to fully lower the dump body by pushing and holding the down button (3) and then pull the trailer forward and then repeat the previous step. See figure 5-6.
- Standing well clear of the dump body, raise the dump body to the **three quarter point** of the maximum dump angle. Discontinue pushing the up button and walk to the rear of trailer to check to see if there is enough space for continued dumping.
- Repeat the process until the load has been completely dumped.
- If the load has not completely dumped DO NOT drive forward and stop quickly to “shock” the load out of the body. Also DO NOT “jerk” the control button up and down to dislodge the load. The proper procedure for a stuck load is to lower the dump and dislodge the material by hand.
- Press and hold the down button (3) to lower the dump body. See figure 5-6.
- Release the button when the dump body is fully lowered. Place dump body control in the storage or travel location. Close and lock battery box.
- Close and lock rear doors before moving the trailer.

### **5.3 HYDRAULIC COMPONENTS**

Do not alter or substitute and hydraulic components on the dump trailer. The hoist system is designed with each component being compatible with the safe and reliable operation of the hoist system. Under no circumstances should you alter the hydraulic pressure or flow rate to the hoist system.

# Loading And Unloading A Dump Trailer

## Danger

**NEVER** alter or substitute any hydraulic system component. Death or serious injury may result.

An altered or component substituted hydraulic system may malfunction, resulting in the dump body falling without warning.

**NEVER** alter or substitute any hydraulic system component.

Always have the hoist system repaired or maintained by a qualified technician.

## 5.4 BODY PROP

The body prop supplied as part of the trailer is to be used only when the dump body is empty. The purpose of the body prop is a back-up to the hydraulic system and will hold the empty dump body in a raised position while performing maintenance on the hoist, trailer body, or the trailer itself.

**DO NOT** use the body prop to support a loaded dump body.

**DO NOT** perform maintenance under a raised dump body without first blocking the empty dump body up with the body prop.

## Danger

Risk of death by crushing.

Empty dump body before using body prop.

## WARNING

Risk of death by crushing.

Make sure dump body is empty.

**DO NOT** manipulate the body prop if a person is near the control.

## Loading And Unloading A Dump Trailer

### WARNING

Risk of death by crushing.  
Dump body can drop unexpectedly.  
Never go under a raised dump body.  
Use body prop for maintenance.

Park the trailer on a firm and level surface. Raise the dump body and lock the body prop in the upright position. Lower the dump body onto the body prop.

### **5.5 SECURING THE CARGO**

Since the trailer cargo is subjected to longitudinal (front / back) and lateral (side / side) forces you must secure all cargo, that is not flowable, so that it does not shift while the trailer is being towed.

### WARNING

Shifting cargo can result loss of control of the trailer, and can lead to death or serious injury.  
Tie down all loads with proper sized fasteners, ropes, straps, etc.

Refer to [www.fmsca.dot.gov](http://www.fmsca.dot.gov) for regulations regarding cargo securement rules.

## 6 LOADING AND UNLOADING A FLATBED TRAILER

Improper trailer loading causes many accidents and deaths. To safely load a trailer, you must consider:

- Overall load weight;
- Load weight distribution;
- Proper tongue weight; and
- Securing the load properly.

To determine that you have loaded the trailer within its rating, you must consider the *distribution* of weight, as well as the total weight of the trailer and its contents. The trailer axles carry most of the total weight of the trailer and its contents (Gross Vehicle Weight, or “GVW”). The remainder of the total weight is carried by the tow vehicle hitch. It is essential for safe towing that the trailer tongue and tow vehicle hitch carry the proper amount of the loaded trailer weight, otherwise the trailer can develop an undesirable sway at towing speeds, or the rear of the towing vehicle can be overloaded. Read the “Tongue Weight” section below.

The load distribution must be such that no component part of the trailer is loaded beyond its rating. This means that you must consider the rating of the tires, wheels and axles. For tandem and triple axle trailers, you must make sure that the front-to-rear load distribution does not result in overloading any axle.

Towing stability also depends on keeping the center of gravity as low as possible. Load heavy items on the floor and over the axles. When loading additional items, be sure to maintain even side-to-side weight distribution and proper tongue weight. The total weight of the trailer and its contents must never exceed the total weight rating of the trailer (Gross Vehicle Weight Rating, or “GVWR”).

# Loading And Unloading A Flatbed Trailer

## **WARNING**

An overloaded trailer can result in loss of control of the trailer, leading to death or serious injury.

Do not exceed the trailer Gross Vehicle Weight Rating (GVWR) or an axle Gross Axle Weight Rating (GAWR).

Do not load a trailer so that the weight on any tire exceeds its rating.

## **6.1 GENERAL INFORMATION**

Your flatbed trailer may be equipped with chain boxes on the front of the trailer. The boxes are for storing chains, binders, etc. Do not store items that can blow out while driving in the chain boxes.

Gooseneck trailers may be equipped with steps (1) and grab handles on each side to ease access to, and from the trailer deck. See figure 6-1.

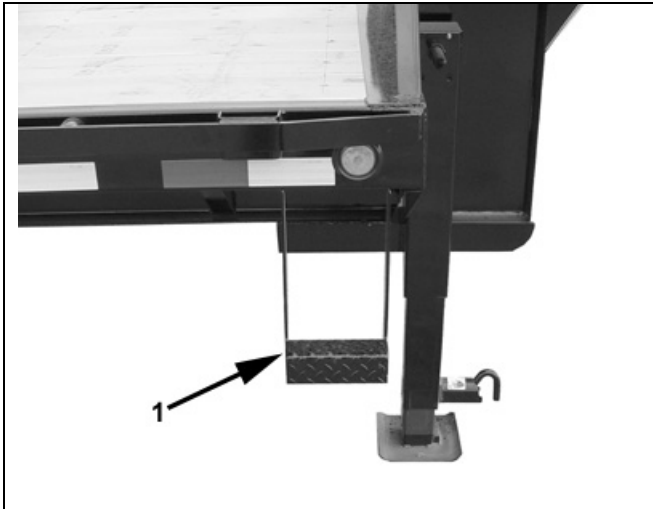

Gooseneck Steps – Figure 6-1

## **6.2 DOVETAIL AND RAMP OPTIONS**

Your flatbed trailer can be equipped with one of several different ramp options:

- Hydraulically operated dovetail.

## Loading And Unloading A Flatbed Trailer

- Fold down ramps.
- Two spring loaded ramps.
- Three spring loaded ramps.
- Removable ramps.
- Mesh ramps.

### WARNING

Unsecured ramps can create a driving hazard.

Secure ramps in their storage or travel position before towing trailer.

### 6.2.1 Hydraulically Operated Dovetail

The hydraulic pump, battery and control are located on the street side of the trailer in a lockable box.

- To lower the dovetail, open the box and locate the control. Press “UP” (1) to move the dovetail off of the mechanical stops. See figure 6-2.



Dovetail Control – Figure 6-2

- Move mechanical stop handle (2) clockwise to move mechanical stops off of cylinder. See figure 6-2.

## Loading And Unloading A Flatbed Trailer

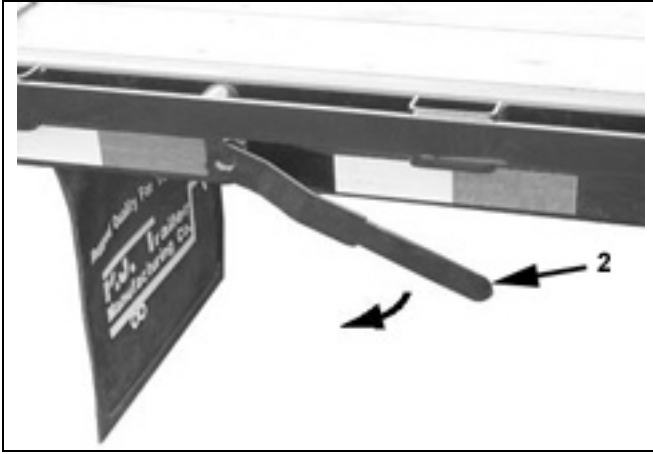

Dovetail Mechanical Stop Handle – Figure 6-3

- Press “OUT” (3) to move the dovetail ramp out. See figure 6-4.
- Press “DN” (4) to lower the dovetail. See figure 6-4.

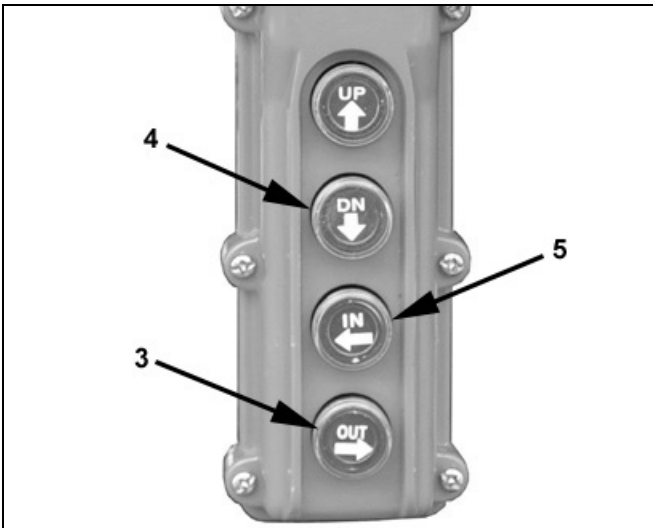

Dovetail Control – Figure 6-4

## Loading And Unloading A Flatbed Trailer



Dovetail Lowered – Figure 6-5

- To raise dovetail:
- Press “UP” (1) to raise dovetail. See figure 6-2.
- Press “IN” (5) to move the dovetail ramp inward. See figure 6-4.
- Move the mechanical stop lever counter clockwise until lever is horizontal. See figure 6-3.
- Press “DN” (4) to lower the dovetail against mechanical stops. See figure 6-4.
- Place control in box, close and lock cover.

### 6.2.2 **Fold Down Ramps**

Your trailer may be equipped with one, two or three fold down ramps.

#### **Caution**

Use a safe lifting procedure to prevent injury when handling ramps.

Ramps are shown in figure 6-6 in the travel/ storage position. Your trailer may have ramps that fold over against the trailer deck for travel. If ramps **do not** fold over against the trailer deck, the straps and safety lock pins shown in figure 6-6 **must** be installed for travel.

To lower ramps, remove safety lock pins (1), support straps (2) and lower ramps. Straps and safety lock pins **must** be installed before towing trailer.

## Loading And Unloading A Flatbed Trailer



Fold Down Ramps – Figure 6-7

### 6.2.3 Spring Loaded Ramps

Your trailer may be equipped with one, two or three spring loaded ramps. Lower the ramps and position as needed to load or unload trailer.

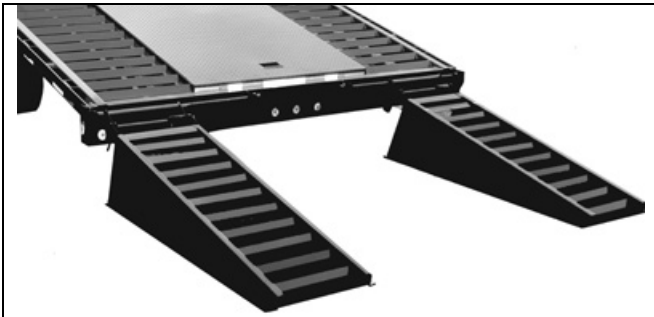

Fold Down Ramps – Figure 6-8

### 6.2.4 Mesh Ramps

Your trailer may be equipped with one, two or three mesh ramps on the rear and/or side of trailer.

## Loading And Unloading A Flatbed Trailer

### Caution

Use a safe lifting procedure to prevent injury when handling ramps.

To lower ramps, remove safety lock pins, support straps and lower ramps. Straps and safety lock pins **must** be installed **or** the ramps **must** be folded over flat against the trailer deck before towing trailer.

#### **6.2.5 Removable Ramps**

Your trailer may be equipped with removable ramps, which may be stored under the rear or side of trailer.



Rear Storage Position Ramps – Figure 6-9

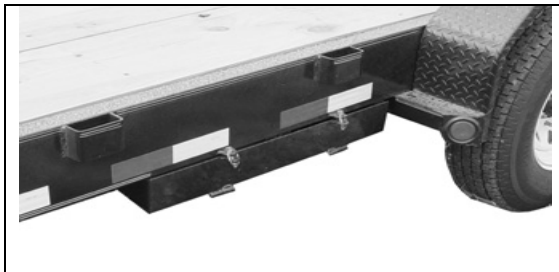

Side Storage Position Ramps – Figure 6-10

## Loading And Unloading A Flatbed Trailer

### Caution

The weight of each loading ramp is listed below.

12 x 60" - 50 lbs.

16 x 60" - 60 lbs

16 x 80" - 80 lbs.

16 x 96" - 100 lbs.

Use a safe lifting procedure to prevent injury when handling ramps.

To install ramps, remove safety lock pins, open covers and pull ramps out. Place angle bracket (1) on ramps, in channel (2) on trailer. See figure 6-11. Adjust ramp width as needed to load and unload trailer.

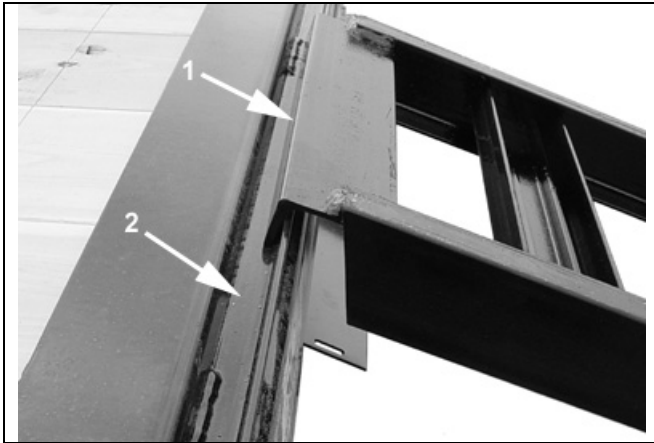

Install Ramps – Figure 6-11

### **6.3 DISTRIBUTING THE CARGO**

Couple the trailer to the tow vehicle before loading. This is essential for the bumper pull trailer because the tongue of a bumper pull trailer can rise during loading, before the cargo is properly distributed. To measure the tongue weight, you will have to uncouple the trailer after it is loaded.

Do not transport people, containers of hazardous substances, cans or containers of flammable substances, such as gasoline, kerosene, paint,

## Loading And Unloading A Flatbed Trailer

etc. The exception is fuel in the tank of vehicles or equipment that are being hauled.

### WARNING

Do not transport flammable, explosive, poisonous or other dangerous materials on your trailer. The exception is fuel in the tank of vehicles or equipment that are being hauled.

### **6.3.1 Preparing the Trailer for Loading**

Before loading cargo onto the trailer:

- Inspect the deck of the trailer for corrosion or damage; and
- Inspect the hold down openings and/or “D”-rings. Hold down openings must be sturdy with no visible cracks or kinks. D-rings must be tight to the deck and must not be bent.

If the deck or any required hold-down is damaged, do not load the cargo. Bring the trailer to your dealer or a competent repair service before using it to carry cargo.

### WARNING

Damaged or loose hold downs and/or “D”-rings can break, allowing cargo to become loose on the trailer. Loose cargo can shift the center of gravity, and result in loss of control of the trailer.

Inspect hold downs and/or “D”-rings, and test them for looseness before loading cargo.

Do not use a damaged or loose hold down or “D”-ring to secure cargo.

### **6.3.2 Loading a Rigid-Deck Trailer**

Before loading trailer, couple the trailer to the tow vehicle and make sure the deck is level. Do not load or unload the trailer when the deck is not level.

Make sure the top of the ramp (or ramps) is secure to the trailer, and the bottom is resting on firm ground.

## Loading And Unloading A Flatbed Trailer

### WARNING

Load can suddenly move or topple, which can result in death or serious injury.

Do not load or unload your open trailer unless it is prevented from tipping and is on firm and level ground.

Load the cargo onto the trailer with approximately 60% of the cargo in the front half of the trailer.

Secure the cargo to the trailer using appropriate straps, chains and tensioning devices.

Since the trailer “ride” can be bumpy and rough, you must secure your cargo so that it does not shift while the trailer is being towed.

### WARNING

Shifting cargo can result in loss of control of the trailer, and can lead to death or serious injury.

Tie down all loads with proper sized fasteners, ropes, straps, etc.

Return the ramp(s) to their stowed position(s), and secure them so that they will not move during transit.

### **6.3.3 Loading a Tilt Deck Trailer**

The pivoting-deck trailer is fitted with a spring-loaded catch that keeps the trailer in the driving position. After the trailer is loaded and the cargo is secured with hold downs, be sure the spring-loaded catch has locked the trailer into “driving position.”

Couple the trailer securely to the tow vehicle before attempting to unlock the deck and load the trailer.

Unlock the deck and pivot it to the Loading position. Before loading the cargo, be certain the deck catch pin is retracted.

## Loading And Unloading A Flatbed Trailer

### WARNING

Loading a pivoting-deck trailer before retracting the deck catch pin can crack the catch pin, which can cause loss of cargo or loss of control of the trailer. Death or serious injury may result.

Before loading the trailer, retract the deck catch pin.

If the deck catch pin becomes bent, do not straighten it. Replace the deck catch pin before towing the load.

Load the cargo onto the trailer with approximately 60% of the cargo in the front half of the deck. As the cargo is moved forward on the deck, the deck will pivot down into the driving position.

Extend the deck catch pin into the deck to lock the deck into the driving position. Ensure that the catch engages the hole in the pivoting deck.

### WARNING

An unlocked pivoting deck can result in loss of cargo or loss of control of the trailer, which can result in death or serious injury.

Before towing the trailer:

- Lock the pivoting deck in the driving position.
- Double-check that the catch engages the hole in the pivoting deck.

Secure the cargo onto the trailer using appropriate straps and tensioning devices.

# 7 CHECKING THE TRAILER BEFORE AND DURING EACH TOW

## 7.1 PRE-TOW CHECKLIST

Before towing, double-check all of these items:

- Tires, wheels and lug nuts. See the “Major Hazards” section of this manual.
- Tire Pressure. Inflate tires on trailer and tow vehicle to the pressure stated on the Certification / VIN label.
- Coupler secured and locked. See “Coupling To The Tow Vehicle” section of this manual.
- Safety chains properly rigged to tow vehicle, not to hitch or ball. See “Coupling to the Tow Vehicle” section of this manual.
- Test Tail, Stop, and Turn Lights
- Test trailer brakes.
- Safety breakaway switch cable fastened to tow vehicle, not to safety chains. See “Coupling to the Tow Vehicle” section of this manual)
- Cargo properly loaded, balanced and tied down. See the appropriate “Loading The Trailer” section of this manual.
- Tongue weight and weight distribution set-up.
- Doors and gates latched and secured
- Fire extinguisher
- Flares and reflectors

## 7.2 MAKE REGULAR STOPS

After each 50 miles, or one hour of towing, stop and check the following items:

- Coupler secured
- Safety chains are fastened and not dragging
- Cargo secured
- Cargo door latched and secured

## 8 BREAKING-IN A NEW TRAILER

### 8.1 RETIGHTEN LUG NUTS AT FIRST 10, 25 & 50 MILES

Wheel lugs can shift and settle quickly after being first assembled, and must be checked after the **first** 10, 25 and 50 miles of driving. Failure to perform this check may result in a wheel coming loose from the trailer, causing a crash leading to death or serious injury. Refer to Section 10.2.12.

#### **WARNING**

Lug nuts are prone to loosen after being first assembled. Death or serious injury can result.

Check lug nuts for tightness on a new trailer, and after re-mounting a wheel at 10, 25 and 50 miles.

### 8.2 ADJUST BRAKE SHOES AT FIRST 200 MILES

Brake shoes and drums experience a rapid initial wear. The brakes must be adjusted after the first 200 miles of use, and each 3,000 miles thereafter. Some axles are fitted with a mechanism that will automatically adjust the brake shoes when the trailer is “hard braked” from a rearward direction. Read your axle and brake manual to see if your brakes adjust automatically. If you do not have the axle and brake manual, call PJ Trailers at 800-452-9116 for a free copy.

A hard stop is used to:

- Confirm that the brakes work;
- Confirm that the trailer brakes are properly synchronized with the tow vehicle brakes using the brake controller in the tow vehicle
- Adjust the brake shoes as necessary.
- For surge brakes check the Master cylinder reservoir for fluid.

## Breaking-in a New Trailer

If your trailer is not fitted with automatically adjusting brakes, the brakes will need to be manually adjusted. See section 10.2.3.2, “Manually Adjusting Brake Shoes,” for instructions.

### **8.3 SYNCHRONIZING THE BRAKE SYSTEMS**

Trailer brakes are designed to work in synchronization with the brakes on the tow vehicle. When the tow vehicle and trailer braking systems are synchronized, both braking systems contribute to slowing, and the tongue of the trailer will neither dive nor rise sharply.

#### **WARNING**

If trailer and tow vehicle brakes do not work properly together, death or serious injury can occur.

Road test the brakes in a safe area at no more than 30 m.p.h. before each tow

To insure safe brake performance and synchronization, read and follow the axle/brake and the brake controller manufacturers’ instructions. If you do not have these instructions, call PJ Trailers at 800-452-9116 for a free copy.

### **8.4 TIRE PRESSURE**

Check tire pressures on both the trailer and tow vehicle. Inflate to the pressure stated on the vehicles’ Certification / VIN label.

## 9 ACCESSORIES

This chapter provides some basic information for the safe operation of accessories. You must read and follow these instructions before using the accessory. If you are uncertain whether you have all of the instructions, call PJ Trailers at 800-452-9116 before operating the accessory.

### **9.1 ACCESSORY BATTERY**

Your trailer may be outfitted with an accessory battery that operates lighting, dump body or other accessories. An accessory battery may be kept charged either by the tow vehicle or by using an external battery charger.

A disconnect switch may be provided to disconnect the accessory battery when you do not plan to be using the trailer for an extended period, such as seasonal storage. If there is no disconnect switch, then remove the cables from the battery terminals.

The accessory battery must be kept in a charged condition during storage. The battery could freeze and break if it becomes discharged.

# 10 INSPECTION, SERVICE & MAINTENANCE

## **10.1 INSPECTION, SERVICE & MAINTENANCE SUMMARY CHARTS**

You must inspect, maintain and service your trailer regularly to insure safe and reliable operation. If you cannot or are unsure how to perform the items listed here, have your dealer do them. Note: In addition to this manual, also check the relevant component manufacturer's manual.

## Accessories

### Inspection and Service before Each Use

Item	Inspection / Service	Manual Section Reference
<b>Breakaway Brakes</b>		
> Electric	Check operation	Sections 4.3.4 & 4.4.5
> Hydraulic	Check fluid level	Section 10.2.3.6
<b>Breakaway Battery</b>	Fully charged, connections clean	Sections 4.3.4 & 4.4.5 Section 10.2.3.3
<b>Brakes, all types</b>	Check operation	Section 8.3
<b>Shoes and Drums</b>	Adjust	Section 8.2 10.2.3.2
<b>Brakes, Hydraulic – Vacuum Actuated</b>	Check gauge for proper vacuum of 18 In. Hg. (inches of mercury)	Section 10.2.3.6
<b>Coupler and Hitch Ball</b>	Check for cracks, pits, and flats. Replace w/ball & coupler having trailer GVW Rating.  Grease.  Check locking device & replace when worn.	Section 4.3.1.2  Section 4.3.1.2 Section 10.2.4.1
<b>Gooseneck Ball</b>	Check for cracks, pits, and flats. Replace w/ball & coupler having trailer GVW Rating.  Grease.  Check locking device & replace when worn.	Section 4.4.2  Section 4.4.2 Section 10.2.4.3
<b>Ring &amp; Pintle</b>	Check for cracks, pits and flats. Replace w/ring and pintle having trailer GVW rating  Grease.  Check locking device & replace when worn.	Section 4.3.2.1  Section 4.3.2.1 Section 10.2.4.2
<b>Safety Chain(s) &amp; Hooks</b>	Check for wear and damage	Sections 4.3.3 & 4.4.4

## Accessories

<b>Tires</b>	<b>Check tire pressure when cold. Inflate as needed.</b>	<b>Sections 7.1 &amp; 10.2.8</b>
<b>Wheels - Lug Nuts (Bolts) &amp; Hub</b>	<b>Check for tightness Tighten. For new and remounted wheels, check torque after first 10, 25 &amp; 50 miles of driving and after any impact</b>	<b>Section 7.1 Sections 8.1 &amp; 10.2.12</b>

### Inspection and Service each Month

<b>Item</b>	<b>Inspection / Service</b>	<b>Manual Section Reference</b>
<b>Lubrication</b>	<b>Lubricate doors and dump body pivots</b>	<b>Section 10.2.11</b>

### Inspection and Service each 6 Months or 6,000 Miles

<b>Item</b>	<b>Inspection / Service</b>	<b>Manual Section Reference</b>
<b>Tires</b>	<b>Rotate @ 5,000 miles</b>	<b>Section 10.2.8</b>
<b>Brakes, electric</b> <ul style="list-style-type: none"> <li>&gt; Magnets</li> <li>&gt; Controller (in tow vehicle)</li> </ul>	<b>Check wear and current draw Check power output (amperage) and modulation</b>	<b>Section 10.2.3.5 Section 10.2.3.4 See Controller Mfr's Manual</b>
<b>Tires</b>	<b>Inspect tread and sidewalls thoroughly. Replace tire when treads are worn, when sidewall has a bulge, or sidewall is worn</b>	<b>Section 10.2.8 Section 10.2.8</b>

## Accessories

Inspection and Service Each Year or 12,000 Miles

Item	Inspection / Service	Manual Section Reference
<b>Brakes, all types</b> > Shoes and drums	Check for scoring and wear. Replace per manufacturer's specifications	Section 10.2.3.1 See Brake Mfr's Manual
<b>Jack, Drop-leg</b>	Grease gears at top	See Jack Mfr's Manual
<b>Structure</b> > Frame members > Welds	Inspect all frame members, bolts & rivets. Repair or replace damaged, worn or broken parts.  Inspect all welds. Repair as needed	Section 10.2.1  Section 10.2.2.2
<b>Wheels</b> > Wheel Bearings  > Rims	Disassemble / inspect / assemble and repack. Replace promptly if immersed in water  Inspect for cracks & dents. Replace as needed.	Section 10.2.10 & See Axle Mfr's Manual  Section 10.2.9
<b>Structure</b> > Axle Attachment Bolts	Check BY DEALER	Section 10.2.1

## **10.2 INSPECTION AND SERVICE INSTRUCTIONS**

### **10.2.1 Axle Bolts, Frame, Suspension, & Structure**

#### **WARNING**

Worn or broken suspension parts can cause loss of control and injury may result.

Have trailer professionally inspected annually and after any impact.

To perform many of the inspection and maintenance activities, you must jack up the trailer.

## Accessories

When jacking and using jack stands, place them so as to clear wiring, brake lines, and suspension parts (springs, torsion bars, etc.). Place jacks and jack stands under the outer frame rail to which the axles are attached.

### WARNING

Never crawl under your trailer unless it is on firm and level ground and resting on properly placed and secured jack stands.

### **10.2.2 Trailer Structure**

Because the trailer floor receives the most abuse, it will most likely corrode before any other part of the structure.

Using a power washer and a detergent solution, wash the floor and walls of the trailer. Rinse the trailer floor and walls.

#### **10.2.2.1 Fasteners and Frame Members**

Inspect all of the fasteners and structural frame members for bending and other damage, cracks, or failure. Repair or replace any damaged fastener and repair the frame member. If you have any questions about the condition or method of repair of fasteners or frame members, get the recommendation of, or have the repair done by, your dealer.

### WARNING

Broken or damaged fasteners or welds can cause injury or damage to trailer and contents.

Inspect for, and repair all damaged parts at least once a year.

#### **10.2.2.2 Welds**

All welds can crack or fail when subjected to heavy loads or movement of cargo that was not properly tied to prevent movement. Any time that you know or suspect that the trailer has been subjected to heavy loads or movement of cargo, immediately inspect the welds and fasteners for damage. To prevent severe damage to your trailer, inspect all of the welds for cracks or failure at least once a year.

## Accessories

### **WARNING**

Broken or damaged fasteners or welds can cause injury or damage to trailer and contents.

Inspect for, and repair all damaged parts at least once a year.

### **10.2.3 Trailer Brakes**

#### **10.2.3.1 Brake Shoes and Drums**

Properly functioning brake shoes and drums are essential to ensure safety. You must have your dealer inspect these components at least once per year, or each 12,000 miles.

The brake shoes must be adjusted after the first 200 miles of use, and each 3,000 miles thereafter. Most axles are fitted with a brake mechanism that will automatically adjust the brake shoes when the trailer is “hard braked” from a rearward direction. Read your axle and brake manual to see how to adjust your brakes. If you do not have this manual, call PJ Trailers at 800-452-9116 for a free copy.

#### **10.2.3.2 Manually Adjusting Brake Shoes**

Some braking systems are not automatically adjusted by hard stopping. These brakes require manual adjustment. The following steps apply to adjust most manually adjustable brakes. Read your axle and brake manual to see how to adjust your brakes. If you do not have this manual, call PJ Trailers at 800-452-9116 for a free copy.

Jack up the trailer and secure it on adequate capacity jack stands.

Be sure the wheel and brake drum rotate freely.

Remove the adjusting-hole cover from the adjusting slot on the bottom of the brake backing plate.

With a screwdriver or standard adjusting tool, rotate the starwheel of the adjuster assembly to expand the brake shoes. Adjust the brake shoes out until the pressure of the linings against the drum makes the wheel very difficult to turn. Note: Your trailer maybe equipped with drop spindle axles. See axle manual for your axle type. You will need a modified

## Accessories

adjusting tool for adjusting the brakes in these axles. With drop spindle axles, a modified adjusting tool with about an 80 degree angle should be used.

Rotate the starwheel in the opposite direction until the wheel turns freely with a slight drag.

Replace the adjusting-hole cover.

Repeat the above procedure on all brakes.

Lower the trailer to the ground.

### **10.2.3.3 Brakes, Electric**

Two different types of electric brakes may be present on the trailer: an emergency electric breakaway system, which acts only if the trailer comes loose from the hitch and the breakaway pin is pulled. The other brake is an electric braking system that acts whenever the brakes of the tow vehicle are applied.

#### **Breakaway Brake**

**Breakaway Battery** - This battery supplies the power to operate the trailer brakes if the trailer uncouples from the tow vehicle. Be sure to check, maintain and replace the battery according to the battery manufacturer's instructions.

**Breakaway Switch** - This switch causes the breakaway battery to operate the electric brakes if the trailer uncouples from the tow vehicle.

The lanyard for the pull pin is connected to the tow vehicle, and the switch is connected to the trailer. To check for proper functioning of the switch, battery and brakes, you must pull the pin from the switch and confirm that the brakes apply to each wheel. You can do this by trying to pull the trailer with the tow vehicle, after pulling the pin. The trailer brakes may not lock, but you will notice that a greater force is needed to pull the trailer.

## Accessories

### WARNING

If electric breakaway brakes do not operate when trailer is uncoupled from the tow vehicle, death or serious injury can occur.

Check emergency breakaway brake system BEFORE each tow.

#### **10.2.3.4 Tow Vehicle Operated Electric Brakes**

The electric brakes that operate in conjunction with the tow vehicle brakes must be “synchronized” so that braking is properly distributed to the tow vehicle brakes and the trailer brakes. For proper operation and synchronization, read and follow the axle/brake and the brake controller manufacturers’ instructions. If you do not have these instructions, call PJ Trailers at 800-452-9116 for a free copy.

#### **10.2.3.5 Magnets for all Electric Brakes**

To make certain an electrically-operated braking system will function properly, you must have your dealer inspect the magnets at least once a year, or each 12,000 miles. See the brake manual for wear and current inspection instructions.

#### **10.2.3.6 Brakes, Hydraulic (vacuum, air or electric operated)**

If your trailer has hydraulically-operated brakes, they function the same way the hydraulic brakes do on your tow vehicle. The hydraulic braking system must be inspected by a dealer, at least as often as the brakes on the tow vehicle, but no less than once per year. This inspection includes an assessment of the condition and proper operation of the wheel cylinders, brake shoes, brake drums and hubs.

You must check the fluid level in the master cylinder reservoir at least every three months. If you tow your trailer an average of 1,000 miles per month in a hot and dry environment, you must check the brake fluid level once a month. The brake fluid reservoir is located on the tongue of the trailer or near the gooseneck. Fill with DOT 4 brake fluid.

**Vacuum-Operated Hydraulic** - When towing a trailer, the vacuum gauge, which is located inside the cab of the tow vehicle, must indicate 18 In. Hg. (inches of mercury) or more at all times.

## Accessories

### WARNING

Vacuum gauge in tow vehicle must be at or above 18 In. Hg. If not, brakes may be rendered inoperable and unsafe. Low vacuum will cause damage to the brake system.

**Air Pressure-Operated Hydraulic** - Air/hydraulic braking systems are typically used when the tow vehicle has a diesel engine. The tow vehicle has an air compressor that routes the air to an air/hydraulic mechanism, which sends brake fluid to the wheel cylinders.

The air pressure gauge in your tow vehicle indicates the current air pressure. See your tow vehicle manual for the proper air pressure.

**Electrical-Operated Hydraulic** - Electric/hydraulic braking systems, which are mounted on the trailer, use a small electrically-driven pump to generate hydraulic pressure, which operates the brake cylinders. Like electrical brakes, an electric/hydraulic braking system is operated by an electrical signal from the tow vehicle.

### **10.2.4 Trailer Connection to Tow Vehicle**

#### **10.2.4.1 Bumper Pull Coupler and Ball**

The coupler on the trailer connects to the ball attached to the hitch on the tow vehicle. The coupler, ball and hitch transfer the towing forces between the tow vehicle and the trailer. Before each tow, coat the ball with a thin layer of automotive bearing grease to reduce wear and ensure proper operation; and check the locking device that secures the coupler to the ball for proper operation.

See the coupler manufacturer's manual for other inspection and maintenance activities. If you do not have this manual, call PJ Trailers at 800-452-9116 for a free copy.

If you see or feel evidence of wear, such as flat spots, deformations, pitting or corrosion, on the ball or coupler, immediately have your dealer inspect them to determine the proper action to prevent possible failure of

## Accessories

the ball and coupler system. All bent or broken coupler parts must be replaced before towing the trailer.

The coupler handle lever must be able to rotate freely and automatically snap into the latched position. Oil the pivot points, sliding surfaces, and spring ends with SAE 30W motor oil. Keep the ball pocket and latch mechanism clean. Dirt or contamination can prevent proper operation of the latching mechanism.

When replacing a ball, the load rating must match or exceed the GVWR of the trailer.

### **10.2.4.2 Ring and Pintle**

The ring on the trailer connects to the pintle attached to the hitch on the tow vehicle. The ring, pintle and hitch transfer the towing forces between the tow vehicle and the trailer. Before each tow, coat the ring with a thin layer of automotive bearing grease to reduce wear and ensure proper operation; and check the locking device that secures the pintle to the ring for proper operation.

See the pintle manufacturer's manual for other inspection and maintenance activities. If you do not have this manual, call PJ Trailers at 800-452-9116 for a free copy.

If you see or feel evidence of wear, such as flat spots, deformations, pitting or corrosion, on the ring or pintle, immediately have your dealer inspect them to determine the proper action to prevent possible failure of the ring and pintle system. All bent or broken coupler parts must be replaced before towing the trailer.

The pintle handle lever must be able to rotate freely and automatically snap into the latched position. Oil the pivot points, sliding surfaces, and spring ends with SAE 30W motor oil. Keep the ring pocket and latch mechanism clean. Dirt or contamination can prevent proper operation of the latching mechanism.

When replacing a ring, the load rating must match or exceed the GVWR of the trailer.

## Accessories

### **10.2.4.3 Gooseneck Ball Receiver**

The gooseneck receiver on the trailer connects to a hitch-mounted ball on the towing vehicle. The receiver, ball and hitch transfer the towing forces between the tow vehicle and the trailer. Before each tow, coat the ball with a thin layer of automotive bearing grease to reduce wear and ensure proper operation; and check the locking device that secures the receiver to the ball for proper operation.

See the gooseneck ball receiver manufacturer's manual for other inspection and maintenance activities. If you do not have a manual for the receiver, call PJ Trailers at 800-452-9116 for a free copy. If you see or can feel evidence of wear, such as flat spots, pitting or corrosion, on the ball or receiver, immediately have your dealer inspect them to determine the proper action to prevent possible failure of the ball and receiver system.

When replacing a ball, the load rating must match or exceed the GVWR of the trailer.

### **10.2.5 Landing Leg or Jack**

If a grease fitting is present, you must use a grease gun to lubricate the jack mechanism. Grease the gears in the top of hand-cranked jacks once a year, by removing the top of the jack and pumping or hand packing grease into the gears.

### **10.2.6 Lights and Signals**

Before each tow, check the trailer taillights, stoplights, turn signals and any clearance lights for proper operation.

## **WARNING**

To avoid collisions, taillights, stoplights and turn signals must work.

### **10.2.7 Accessory Battery**

Your trailer may be outfitted with an accessory battery that operates lighting, electric landing gear or other accessories. An accessory battery

## Accessories

may be kept charged either by the tow vehicle or by an external battery charger.

A disconnect switch may be provided to disconnect the accessory battery when you do not plan to be using the trailer for an extended period, such as seasonal storage. If there is no disconnect switch, then remove the cables from the battery terminals.

The accessory battery must be kept in a charged condition during storage. The battery could freeze and break if it becomes discharged.

### **10.2.8 Tires**

Before each tow, be sure the tire pressure is at the value indicated on the Certification / VIN label. Tire pressure must be checked while the tire is cold. Do not check the tire pressure immediately after towing the trailer. Allow at least three hours for a tire to cool, if the trailer has been towed for as much as one mile. Replace the tire before towing the trailer if the tire treads have less than 2/32 inch depth or the telltale bands are visible.

A bubble, cut or bulge in a side wall can result in a tire blowout. Inspect both side walls of each tire for any bubble, cut or bulge; and replace a damaged tire before towing the trailer.

### **WARNING**

Worn, damaged or under-inflated tires can cause loss of control, injury and damage.

Check tires before each tow.

### **10.2.9 Wheel Rims**

If the trailer has been struck, or impacted, on or near the wheels, or if the trailer has struck a curb, inspect the rims for damage (i.e. being out of round); and replace any damaged wheel. Inspect the wheels for damage every year, even if no obvious impact has occurred.

## Accessories

### 10.2.10 Wheel Bearings

A loose, worn or damaged wheel bearing is the most common cause of brakes that grab.

To check your bearings, jack trailer and check wheels for side-to-side looseness. If the wheels are loose, or spin with a wobble, the bearings must be serviced or replaced.

Refer to the axle manufacturer's information for service and maintenance on the axle.

### 10.2.11 Lubrication Points – Dump Trailers

#### **Danger**

Risk of death by crushing.  
Empty dump body before using body prop.

#### **WARNING**

Risk of death by crushing.  
Dump body can drop unexpectedly.  
Never go under a raised dump body.  
Use body prop for maintenance.

#### **WARNING**

Risk of death by crushing.  
Make sure dump body is empty.  
**DO NOT** manipulate the body safety prop if a person is near the control.

The body prop supplied as part of the trailer is to be used only when the dump body is empty. The purpose of the body prop is a back-up to the

## Accessories

hydraulic system and will hold the empty dump body in a raised position while performing maintenance on the hoist, trailer body, or the trailer itself.

**DO NOT** use the body prop to support a loaded dump body.

**DO NOT** perform maintenance under a raised dump body without first supporting the empty dump body up with the body prop.

Pump grease into the each fitting (1) on the dump body pivot hinges and rear door hinges (2) every month. See figures 8-1 and 8-2.

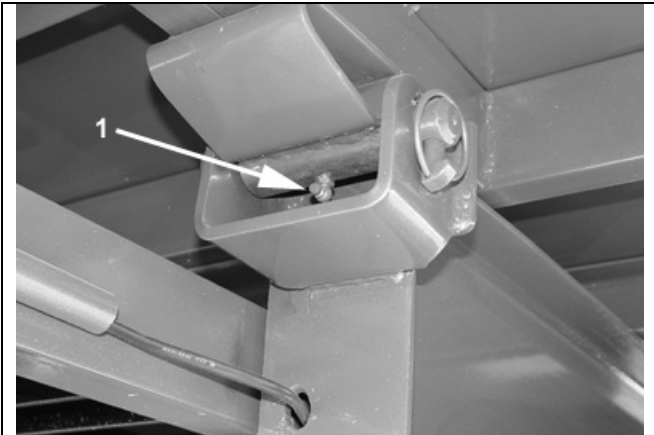

Lubricate Dump Body Pivot Hinges – Figure 8-1

## Accessories

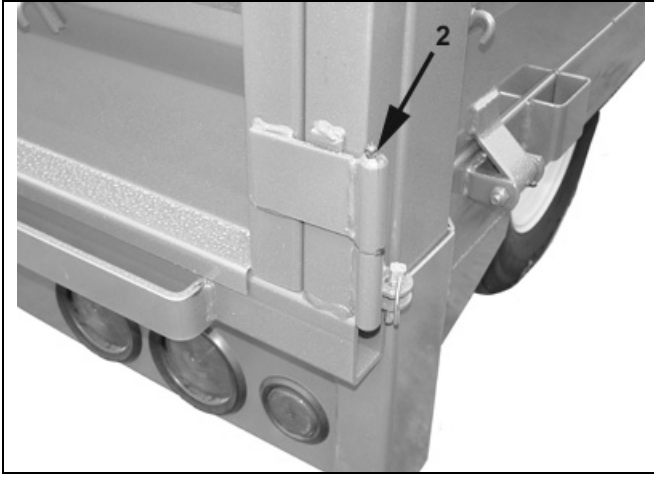

Lubricate Door Hinges – Figure 8-2

Park the trailer on a firm and level surface. Raise the dump body and hold the body safety prop (3) in the upright position. Lower the dump body so the body safety prop engages the socket on the dump body. See figure 8-3. Pump grease into the fittings (4) on each end of the cylinder(s) and in the scissor mechanism (if equipped). The number of grease fittings and location on the scissor mechanism will vary by trailer model.

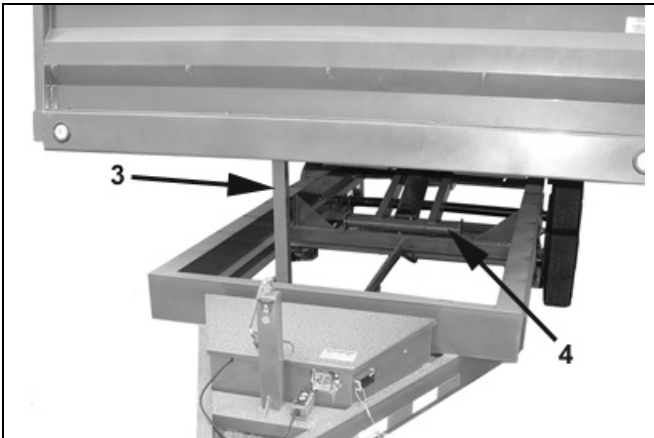

Support Body and Lubricate Cylinder Ends – Figure 8-3

## Accessories

### 10.2.12 Lug Nuts

Lug nuts are prone to loosen right after a wheel is mounted to a hub. When driving on a remounted wheel, check to see if the lug nuts are tight after the first 10, 25 and 50 miles of driving, and before each tow thereafter.

#### WARNING

Lug nuts are prone to loosen after being first assembled. Death or serious injury can result.

Check lug nuts for tightness on a new trailer, and after re-mounting a wheel at 10, 25 and 50 miles.

#### WARNING

Metal creep between the wheel rim and lug nuts (bolts) will cause rim to loosen.

Death or injury can occur if wheel comes off.

Tighten lug nuts (bolts) before each tow.

Tighten the lug nuts to the proper torque for the axle size on your trailer, to prevent wheels from coming loose. Use a calibrated torque wrench to tighten the fasteners. Verify that wheel studs are free of contaminants such as paint or grease, which may result in inaccurate torque readings. Over-tightening will result in breaking the studs or permanently deforming the mounting stud holes in the wheels.

## Accessories

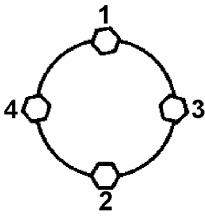

**4 BOLT**

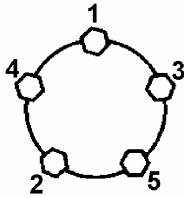

**5 BOLT**

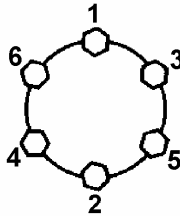

**6 BOLT**

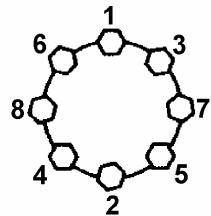

**8 BOLT**

Lug Nut Torque Sequence

Stud Size	Pound Feet of Torque
1/2 inch	80-90
9/16 inch	130-150
5/8 inch cone with tension ring	175-225
5/8 inch two-piece flanged	130-170